

TOOL USE INSTRUCTION

RIVIAN

TOOL NUMBER TSN00553-300

TITLE BATTERY LIFT TABLE JIG

REV - DATE REV 04 - 3/27/2026

CONTENTS

[OVERVIEW](#)

[SAFETY](#)

[INITIAL SETUP](#)

[TOOL CONFIGURATION GUIDE](#)

[TOOL USE INSTRUCTION - BATTERY REMOVAL](#)

[TOOL USE INSTRUCTION - BATTERY INSTALL](#)

[MAINTENANCE & STORAGE](#)

[SYMBOL GLOSSARY](#)

TOOL FUNCTION

TO BE UTILIZED WITH BATTERY LIFT TABLE FOR SUPPORTING HV BATTERY PACKS

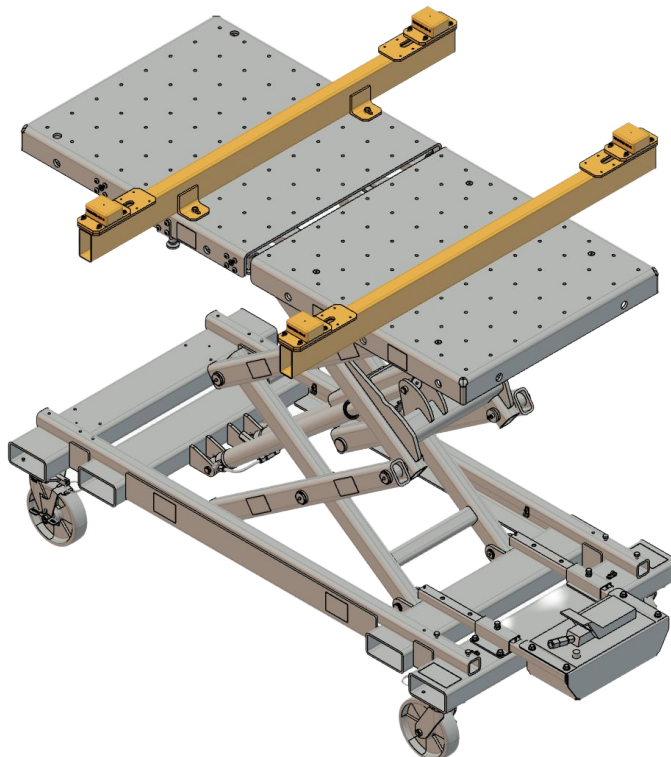

OVERVIEW

SPECIFICATIONS

Manufacturer PN: NCT05389337
Beam Length: 1475mm (58")
Pad Dimensions: 88.9 x 70 mm (3.5 x 2.75")

LABOR CODES

301010010 HV Battery (Remove and Replace)
301010011 HV Battery (Remove and Reinstall)

OTHER TOOLS REQUIRED

TSN00486-100 - Battery Lift Table
TSN00541-300 - Battery Lift Beam
TSN01642-300-A - HV BATTERY GUIDE PIN KIT - R2
TSN00269-101 - 16" Rolling Head Prybar

COMPONENT GUIDE

ITEM	QTY	DESCRIPTION
1	2	CROSS BEAM
2	4	M10 FLANGE BOLT
3	4	SUPPORT PAD
4	4	RISER PAD
5	16	M6 FLANGE BOLT

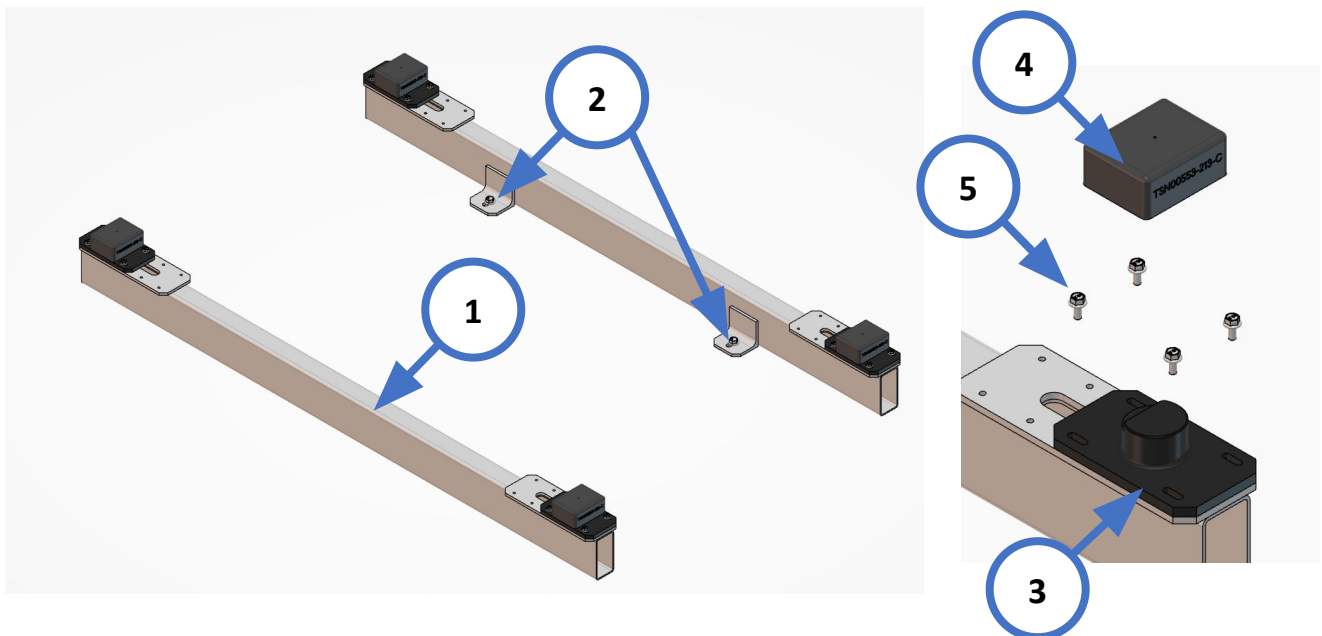







WARNING

Do not perform procedure if tool is damaged or missing parts. Consult the Rivian Service Tool Catalog for replacement components.

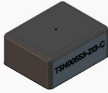
Failure to follow guidelines outlined in this document could result in injury and/or property damage.

SAFETY GUIDELINES

1	Inspect and replace worn or damaged riser pads as needed	
2	Attempting to use lift table to support HV battery packs without jigs in place is not permitted	
3	Ensure pack is supported by all riser pads before fully lowering onto the table	
4	<p>Be cautious of areas where body parts or clothing could get caught or crushed between moving parts of the equipment, potentially causing serious injury.</p> <p>Use spotters and communicate whenever raising or lowering lift table to ensure all pinch points are clear of personnel or objects.</p>	

INITIAL SETUP

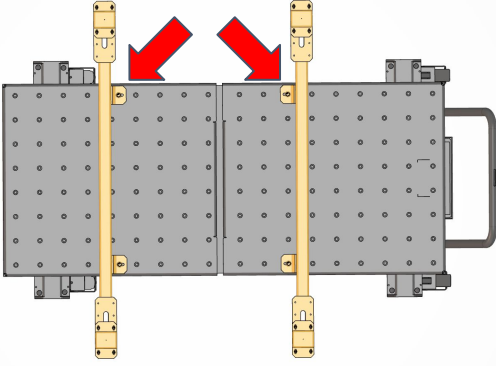
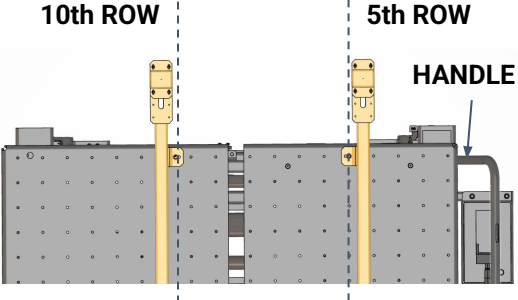
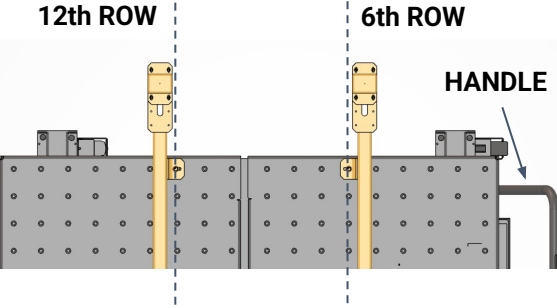
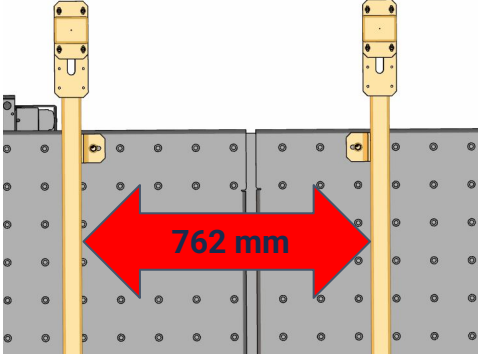
<p>1</p>	<p>Place the cross beams on the table with mounting tabs facing inward as shown.</p>	
<p>2</p>	<p>FOR BOSCH LIFT TABLES:</p> <p>Align cross beam tabs with the 5th row and 10th row of threaded holes, starting from the handle side of the table.</p> <p>FOR WIELANDER AND SCHILL AND ROTARY LIFT TABLES:</p> <p>Align cross beam tabs with the 6th row and 12th row of threaded holes, starting from the handle side of the table.</p>	 
<p>3</p>	<p>Ensure beams are square to the sides of the table, then install 4x M10 fasteners and torque to 22 Nm.</p> <p>Loosen knobs on either side of the table and adjust spacing until center gap between cross beams measures 762 mm (30")</p>	





	FRONT	REAR
<p>C1 NCA ALL VARIANTS</p>		
<p>C3 NCA 7 AND 9 MOD</p>		
<p>LFP BAL TIC</p>		
<p>LFP BENGAL</p>		

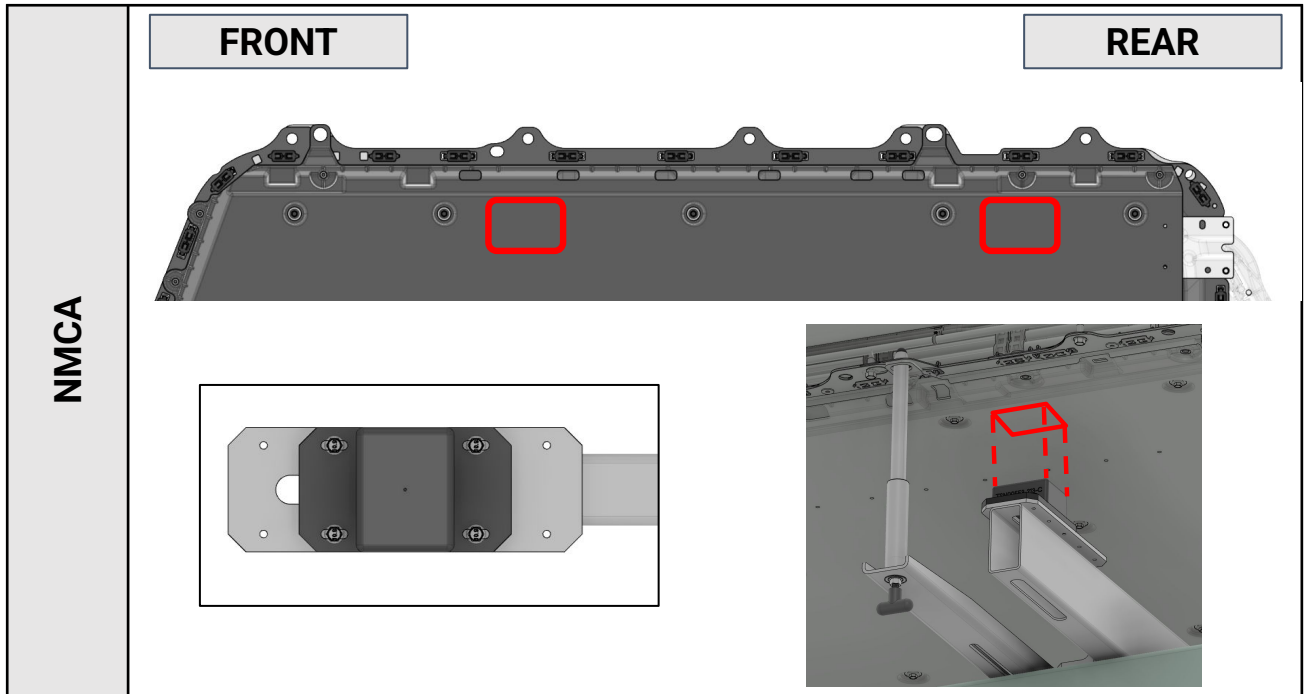



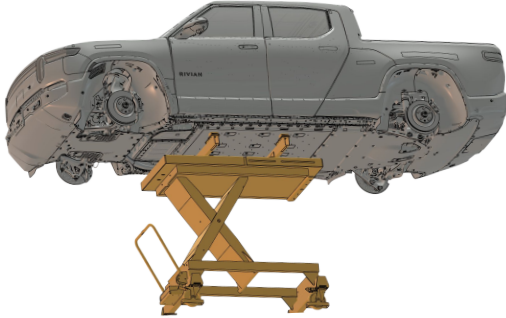
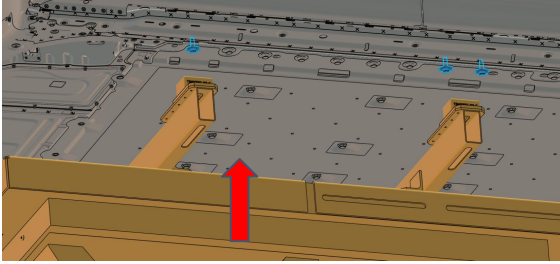

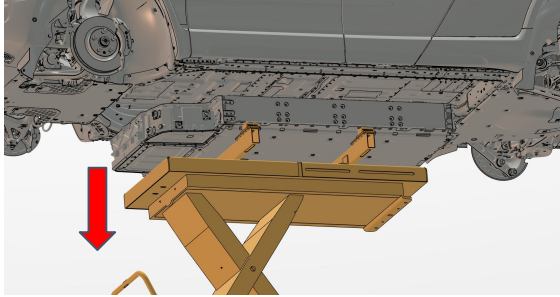
TOOL USE INSTRUCTION - BATTERY REMOVAL

1	<p>Prep vehicle according to service manual procedure</p> <p>Refer to HV Battery Storage, Shipping, and Handling Guide before proceeding</p>	
2	<p>Roll lift table under vehicle with handle + foot pedal toward the front of the vehicle.</p> <p>Attach shop air line to lift table.</p>	
3	<p>Use foot pedal to raise table until pads are approx. 12" from the battery pack flange.</p> <p>Position lift table such that pads are aligned per TOOL CONFIGURATION GUIDE</p> <p>Remove fasteners within contact zone before proceeding.</p>	
4	<p> WARNING</p> <p>2 person operation, one controlling the table and one as spotter at the rear of vehicle</p> <p>Raise table until pads are in contact with the pack flange, ensuring all four pads have even contact.</p> <p>Remove remaining flange fasteners and slowly lower table, checking for interference between the battery and vehicle frame as pack is lowered.</p>	

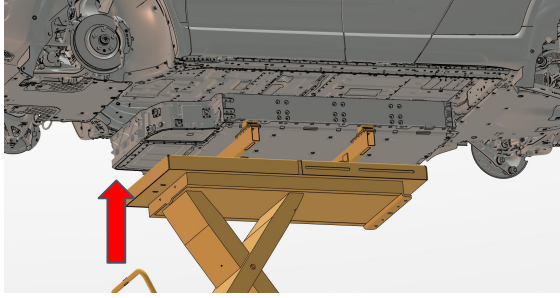
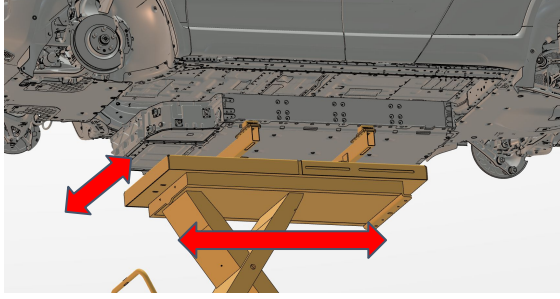

TOOL USE INSTRUCTION - BATTERY INSTALL

<p>1</p>	<p> WARNING</p> <p>2 person operation, one controlling the table and one as spotter at the rear of vehicle</p> <p>Roll lift table under vehicle with front of the pack toward front of vehicle.</p> <p>Use foot pedal to raise table until top of pack is approximately 6" from the bottom of the vehicle.</p>	
<p>2</p>	<p>Adjust lift table position to align pack with vehicle cavity and slowly raise lift table until flange is nearly flush with skateboard mounting surface.</p> <p>NOTE</p> <p>Use side rails of skateboard and brackets in rear to guide pack during install</p>	
<p>3</p>	<p>Use TSN00269-101-A pry bar against pack locating holes to shift lift table front/back as needed until fastener holes are aligned.</p> <p>NOTE</p> <p>Locating feature is a round hole in front, slot in rear</p>	
<p>4</p>	<p>Reinstall all accessible flange fasteners and torque per service manual specifications.</p> <p>Lower lift table, then install remaining fasteners and torque to spec.</p>	



BASIC MAINTENANCE GUIDE

TASK	FREQUENCY
Visually inspect riser pads for signs of damage or excessive wear. Order replacement pads as needed.	Before every use
Store lift table jig indoors in a dry environment	After Each Use

SERVICE & REPLACEMENT COMPONENTS

FOR OTHER ITEMS NOT SHOWN, CONTACT RIVIAN SERVICE TOOL ENGINEERING

ITEM	DESCRIPTION	SUPPLIER	PART NUMBER
1	M10 Flange Bolt	McMaster-Carr	94036A631
2	M6 Flange Bolt	McMaster-Carr	98093A214
3	Riser Pad	Snap-On Punchout	TSN00553-213

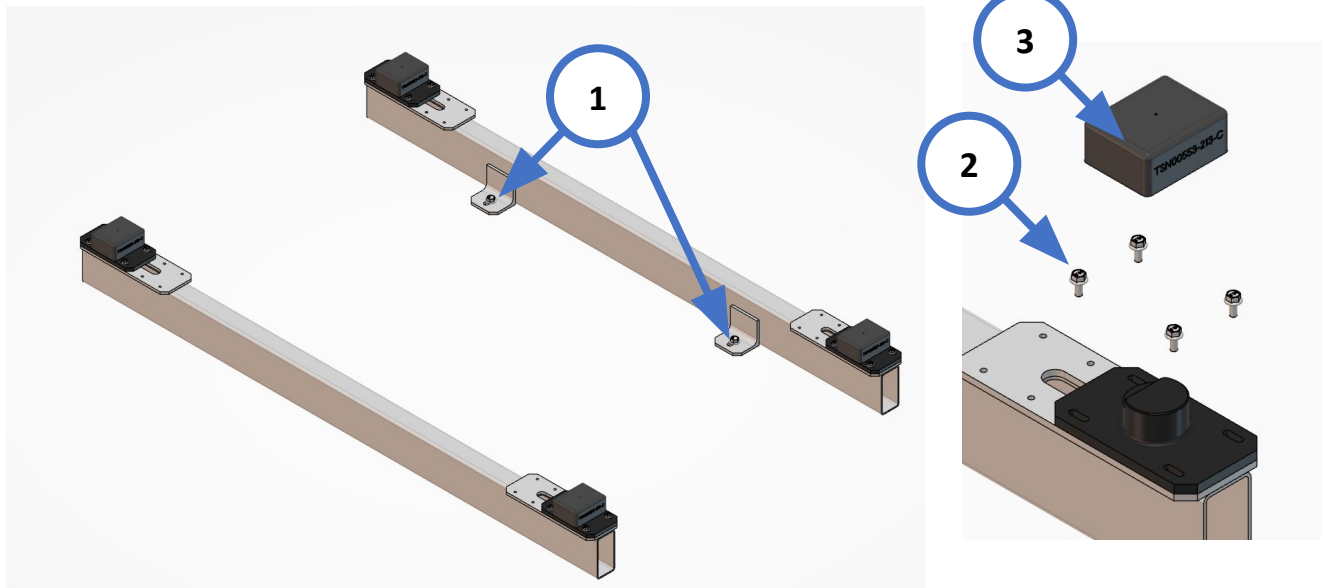

SYMBOL GLOSSARY



WARNING

Risk of minor injury

NOTE

Useful information



PINCH POINT

REVISION LOG

REV	DATE	CHANGE DESCRIPTION
03	12/12/2024	Updated for Rev C tool, translated instructions from confluence to new template
04	3/27/2026	Updated to add R2 config

