

TSN00653 (NCT08821905) - EDV Windshield Removal and Installation

⚠ Attention: This is a draft service manual, provided on a pre-release basis. Many procedures are incomplete. Most procedures have not been verified on a vehicle yet. To provide feedback, email ServiceManualFeedback@rivian.com

⚠ Danger: Risk of bodily injury: This procedure might be missing warnings and cautions that are necessary for safe operation and prevention of damage to the vehicle or equipment.

Important: Due to the incomplete nature of this service manual, it is the reader's responsibility to decide whether a procedure is reasonable, appropriate, and safe to perform. ***Do not begin or continue this repair procedure if you are unsure if it is safe to do so—stop and ask for advice before continuing.***

Table of Contents:

- [Purpose](#)
- [Parts-Required](#)
- [Required-Tooling](#)
- [Removal](#)
 - [Inside-of-vehicle](#)
 - [Outside-of-vehicle](#)
 - [Cutting-out-windshield](#)
- [Installation](#)
- [Video-of-tool-validation-installation-\(Ref-only\)](#)

Purpose:

To assist in removal and installation of RPV 500/700 Windshield.

Parts Required:

Part Number	Description	Quantity
PT00034306	RPV_700/900 Windshield Heated	1
	Rain Sensor	1
Urethane	Approved Service Application Urethane	3 Cartridge Tubes
Primer	Approved Service Application Primer (must match manufacturer of urethane)	2 application containers w/ daubers

Required Tooling:

Equalizer Raptor Kit (Deluxe) or WRD Spider Kit (steel wire is ideal)	
Equalizer Sentinel	
Appropriately sized stand to support windshield	
Step Ladders (x2)	
Suction Cups (x2)	
Battery Operated Urethane dispensing tool (gun)	

Removal:

⚠ Pre work area and have necessary tooling (required tooling list) out to perform the procedure.

Inside of vehicle:

Remove on Driver side:

- A-pillar trim with Driver Monitor
- Cup holder assy

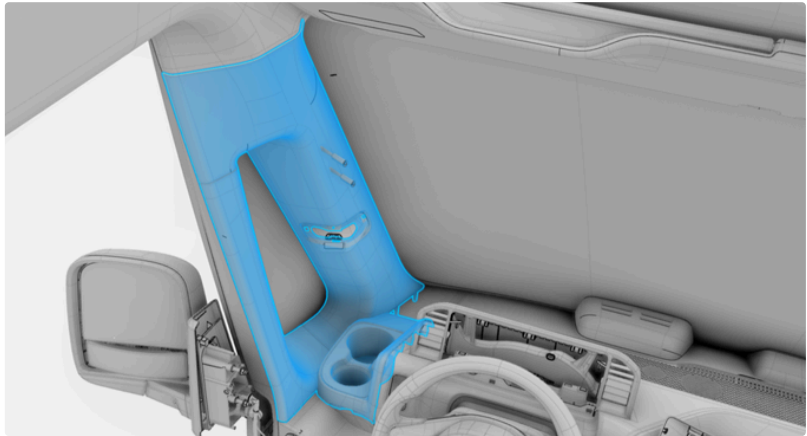

Remove on Passenger side:

- A-Pillar trim
- Grab Handle Assy
- Top dash Storage container Assy

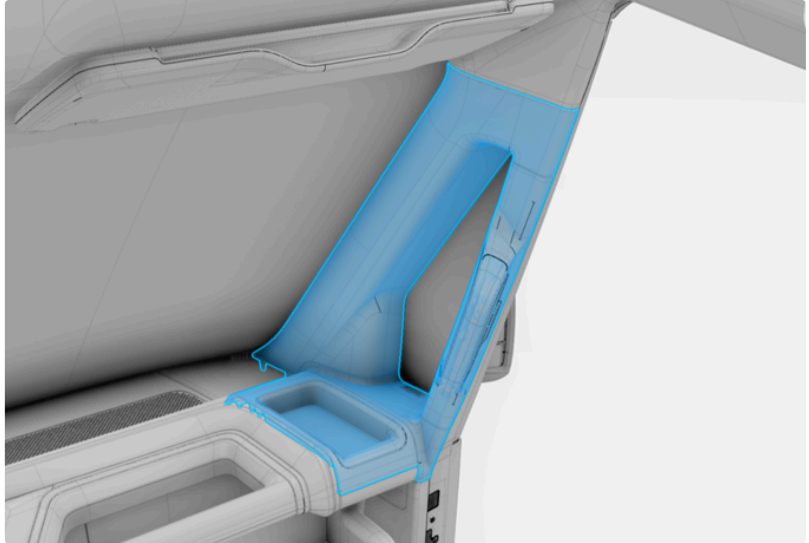

- Remove forward section Upper dash cover extension

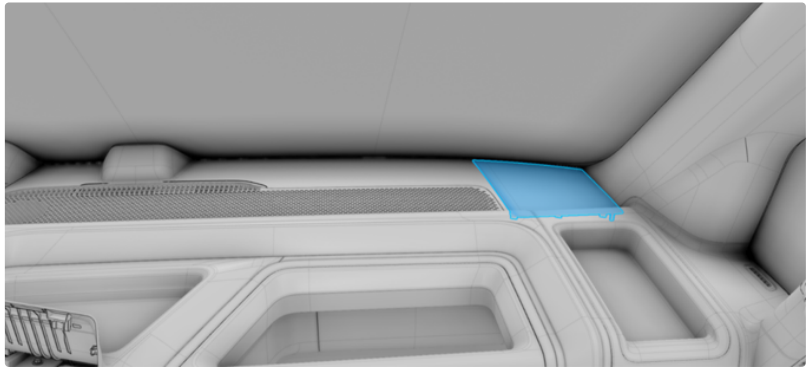

- Remove Camera/sensor cover

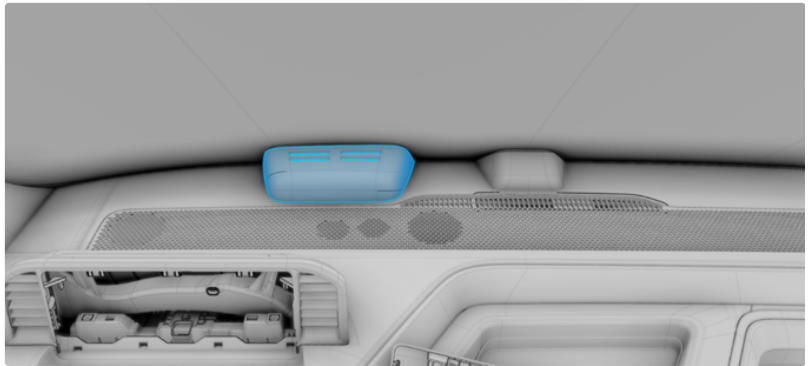

- Remove Upper Dash cover Assy to expose wiring underneath

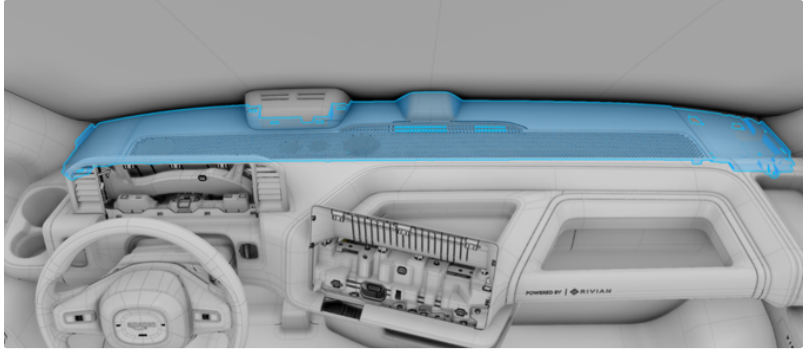

- Disconnect rain sensor plug.

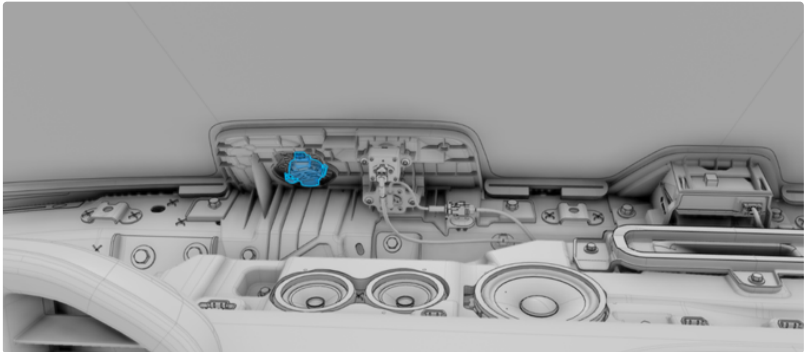

- Unplug the rain sensor harness from the right side of dashboard and remove the harness from the windshield.
- **New Windshield should come with new rain sensor harness (double check to make sure).**

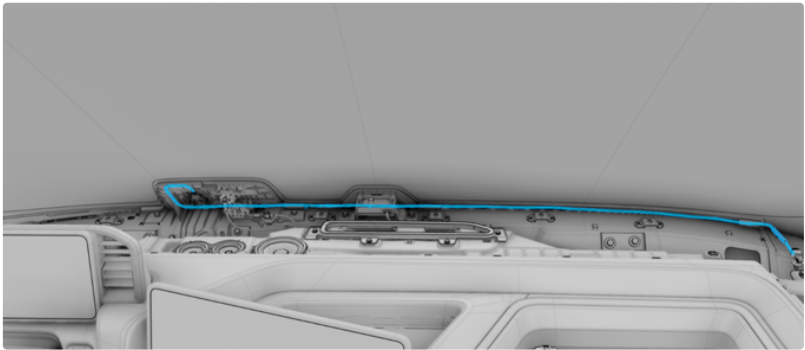

- Un-bolt and loosen the mounting brackets (Driver side bracket can be removed) to allow enough clearance and no tension for the cutting wire to pass through.
- No need to unplug the Cameras.

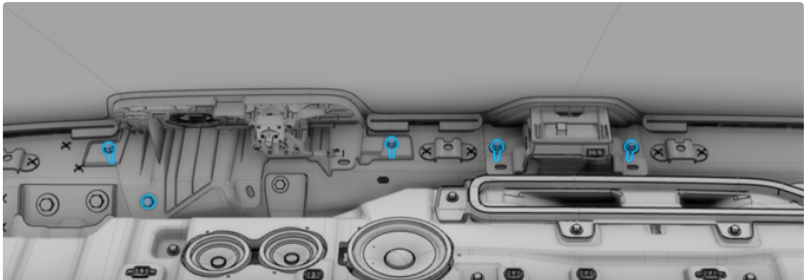

Outside of vehicle:

- Remove Front Grille on fascia



- When removing the Grille Assy.
- Disconnect the water line and Camera plug.
- Leave nozzle and camera attached to Grille Assy

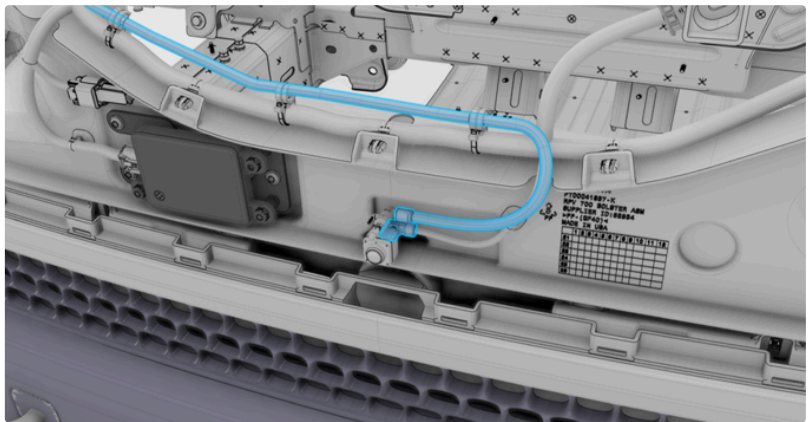

- Remove Front Fascia Assy from vehicle (see Front fascia removal instructions)

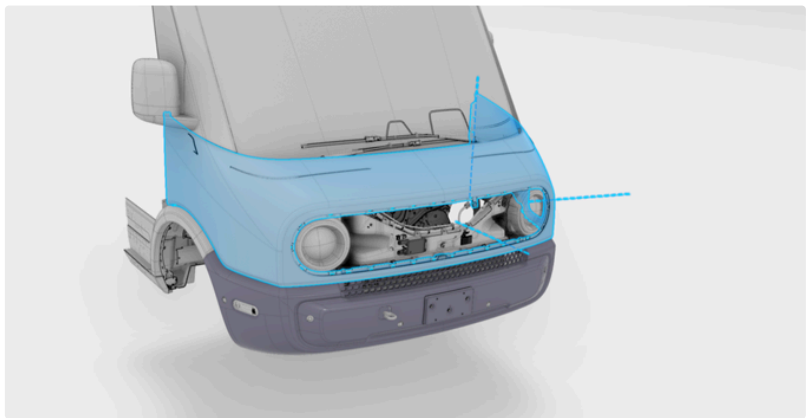

- Remove both Left and Right Exterior A-pillar trims (**be prepared to replace broken clips when removing both assemblies**)



- Remove both Left and Right Wiper Assy

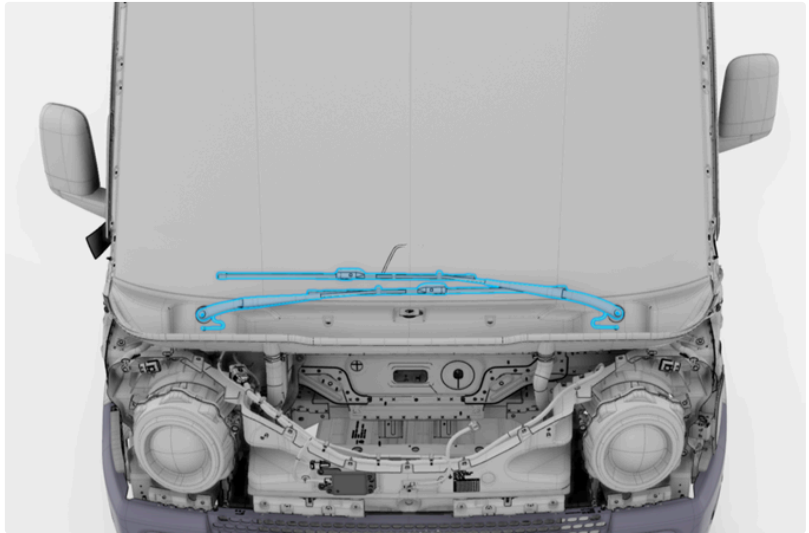

- Disconnect the clamps that hold the LT/ RT Drains to the Cowl

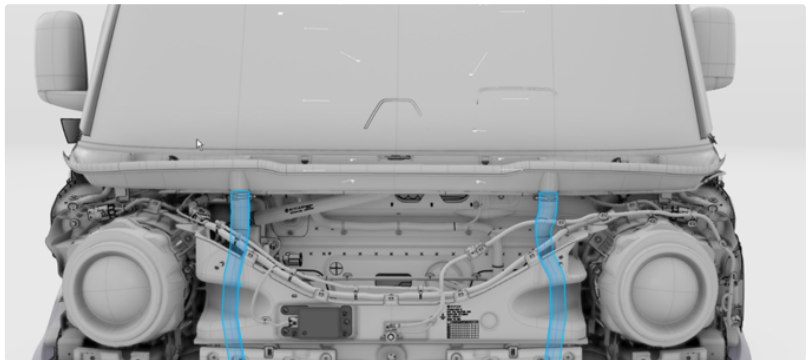

- Disconnect hose from the Washer Bottle and keep with the Cowl Assembly

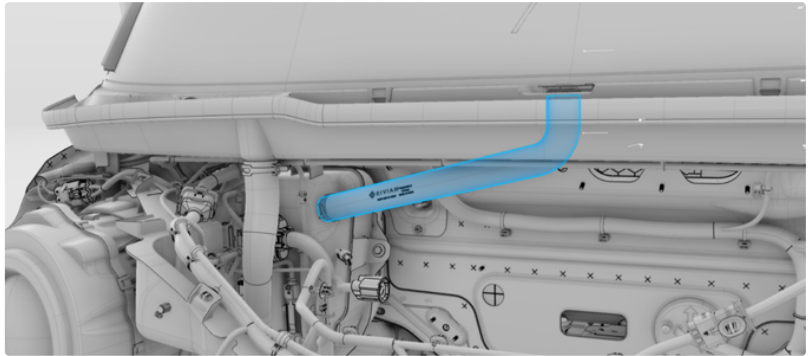

- Remove Cowl Assy (see procedure to remove Cowl Assy)

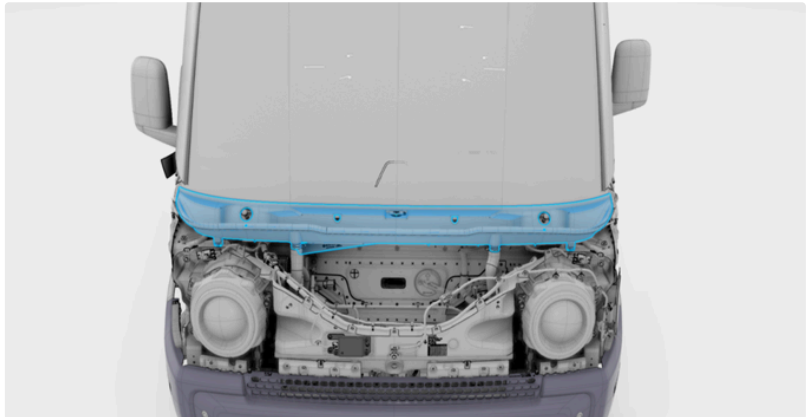

- Un-plug Heater wire Assemblies on both sides and tape pigtail harness to windshield.
- This will get it out of the way during removal.

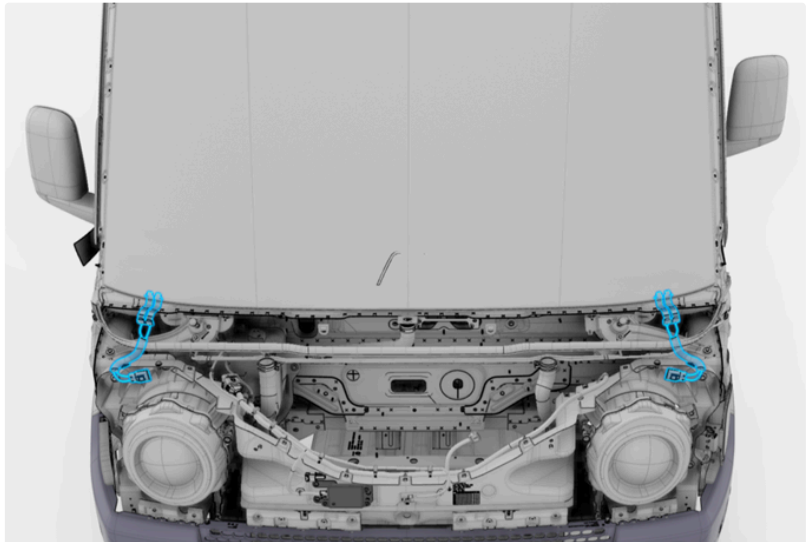

Cutting out windshield:

- ⚠ Follow manufacturer tooling instructions to properly operate the Urethane cutting tool.

- Pull back Headliner a bit and locate the locator pins of the windshield (2X).
- With a flat spatula like tool, de-tach them and remove them.
- This will make it easier for the cutting tool to remove the windshield.



- Insert Cutting wire (with Straight Hook tool) and push cutting wire to the outside from this location.



- With wire reel inside, pull cutting wire to desired length from this location

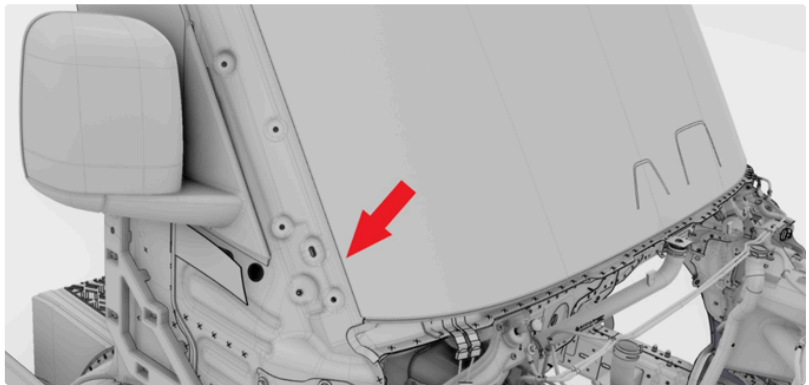

- Route cutting wire from Passenger side around the perimeter of the windshield.
- Ensure that it is under the glass and up against the urethane.

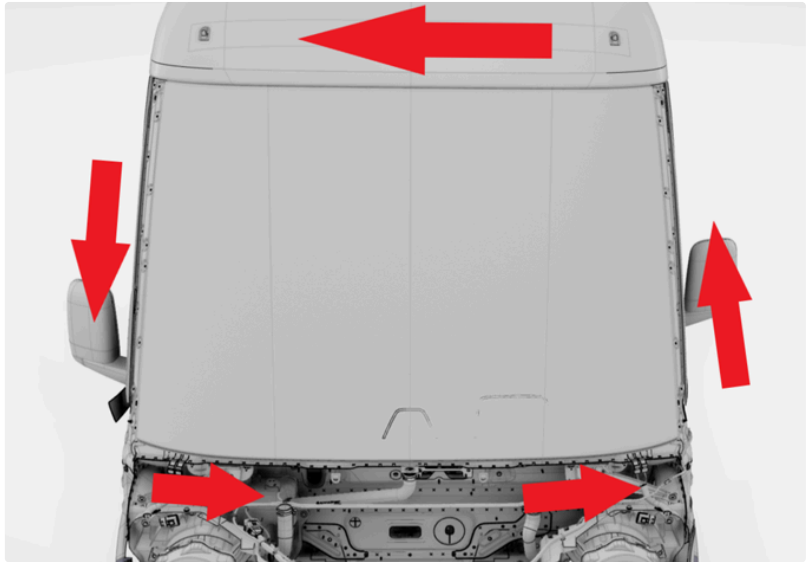

- Overlap cutting wire with where you started at and set the anchor (locked anchor) to the outside of the glass in a position that will keep maximum tension (ideal would be where circle is located).

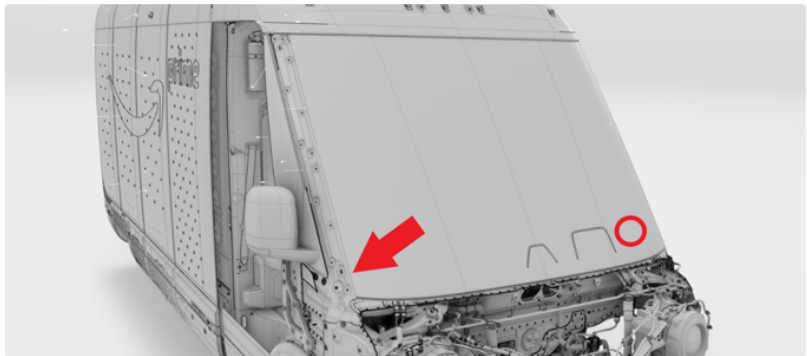

- **Before you start to cut the glass, mount the Equalizer Sentinel tool to the marked area (black box) of the windshield (with the provided suction cups).**
- **Ensure that the center support of the tool (crane) is centered according to the Roof Marker Center Clearance lamp (circled in red).**
- This will ensure proper balance and stability is achieved (adjust Equalizer Sentinel to the widest position for the support legs).



- Tension the Equalizer Raptor and be sure to load the cutting wire into the Raptor turning it the opposite direction

of the cutting wire direction (counter clockwise) and start cutting urethane by applying tension and moving clockwise on the inside (Passenger to driver and around).

- Placement of tooling will depend on preference of technician and the resistance he/she feels in the cutting wire.
- Guide cutting wire against the trim with a wide flexible protector (like a flexible cutting board)
- Once ¼ or 75% of the windshield is cut out, lift the windshield on the cut side partially and put the anchor into the inside of the windshield.
- Make sure that the wire on the anchor side is above (on top off) the Raptor wire and place the anchor on the top right side of the windshield to get best tension for cutting.

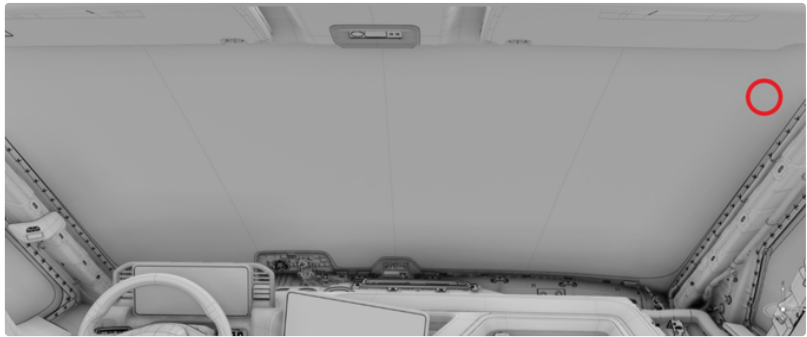
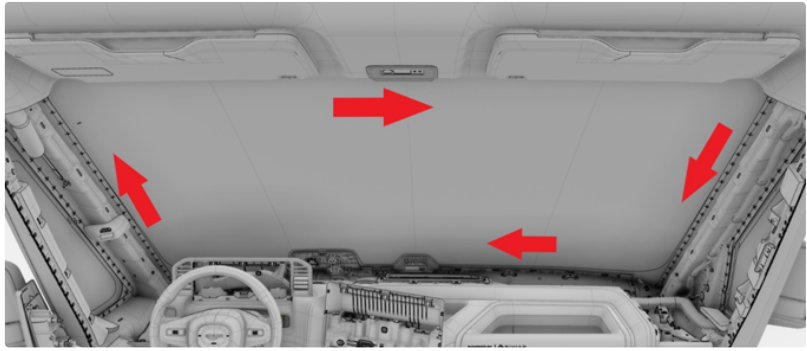

- As cutting wire goes around the windshield, ensure that it does not get caught with the Rain sensor bracket.
- Once the windshield is completely cut out and supported by the Equalizer Sentinel tool, roll back the Equalizer Sentinel and lay the removed windshield on the appropriately sized stand
- Refer to **Installation document (TBD)** on how to properly prepare and prep tooling and the windshield for installation. Specific times need to be met to ensure that proper adhesion and strength requirements are met.

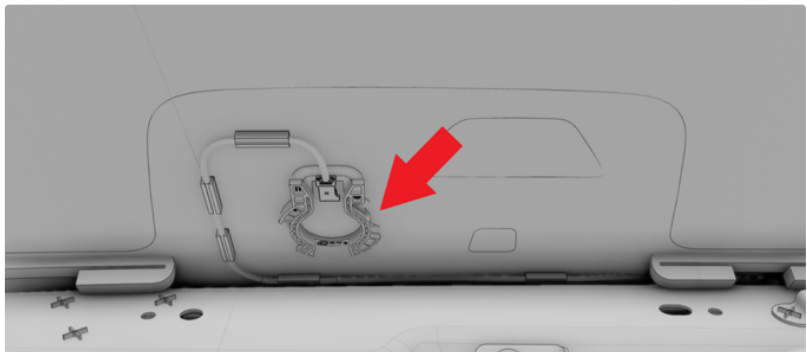

Installation:

- ⚠️ *Prior to installation of the windshield, be aware of the Service Application Urethane Tack Time (time when urethane skins over and is no longer able to bond to a surface), the Service Application Primer Open Time (time that the primer is allowed to be exposed to the open air) and the Drive Away Time (time that the vehicle must sit until it is safe to drive away and the windshield will remain bonded to the vehicle) Drive away time for RPV is DOUBLE the listed Drive Sway time on the service application*

urethane. Temperature and Humidity play a major factor in these times. Prep your surrounding and tools accordingly to properly install the windshield in the required time to ensure that safety is met.

Tack Time and Drive Away Time is the most important metric and upon application of the urethane onto the vehicle you have between 8-12 min. To install the windshield to ensure a proper bond strength. Drive Way Time is **DOUBLE (2X)** the listed drive away time of the service application urethane due to the size and weight of the RPV windshield.

- Install and plug -in a new Rain sensor (or removed one if bring re-used) and route Harness to the appropriate side.
- Tape Harness plug to inside of glass to avoid touching of primer or urethane during installation of Windshield.

⚠ Prep Equalizer Sentinel in the widest stance before mounting windshield.

- Mount the Equalizer Sentinel suction cups in the middle (highlighted) area of the outside of the Windshield.
- Lift the windshield in the desired vertical position and prep to apply Service application primer to the windshield.

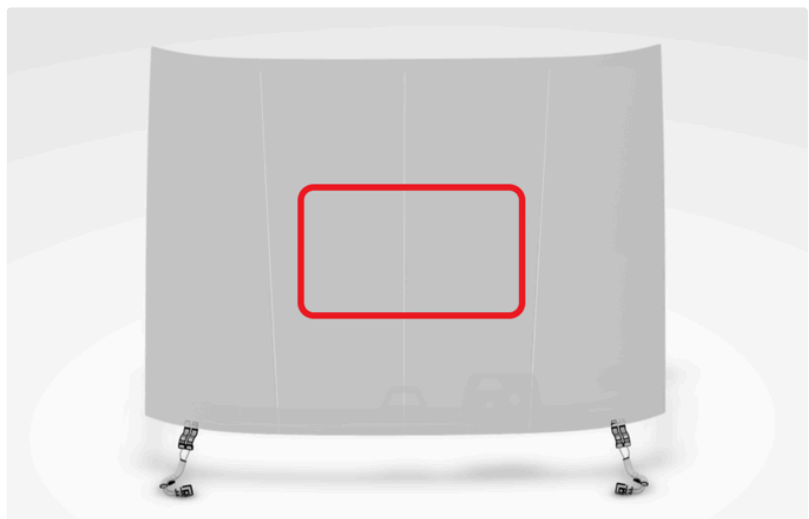

- Prep Windshield by cleaning the bond path and applying the approved Service Application Primer to the Bond Path
- With the windshield in the vertical position (on the Equalizer Sentinel),

start with the bottom of the windshield and work your way around to prevent the initial output of primer from running into the driver's field of view.



- Trim remainder of urethane to 1mm thick all around (consistent height all the way around).
- Apply the service application primer only to the exposed E-coat or bare metal areas in the bond path.

❌ **Do Not** apply primer on top of the old urethane (ideal bonding surface for new urethane)

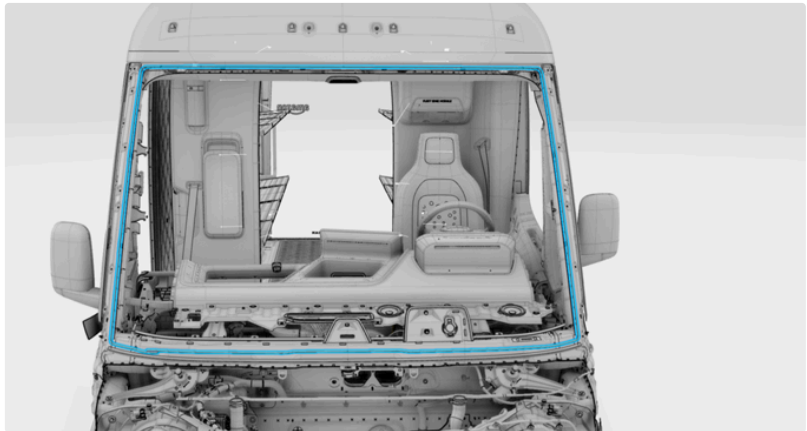

- Mount the camera brackets(x2) but **Do Not** bolt into place. You will secure the camera brackets with the removed fasteners once the glass is already in its place.
- If you do not mount the camera brackets initially, it is difficult to mount the bracket afterwards and you run the risk of pushing against the bottom of the windshield temporarily un-sealing the glass to the surface.

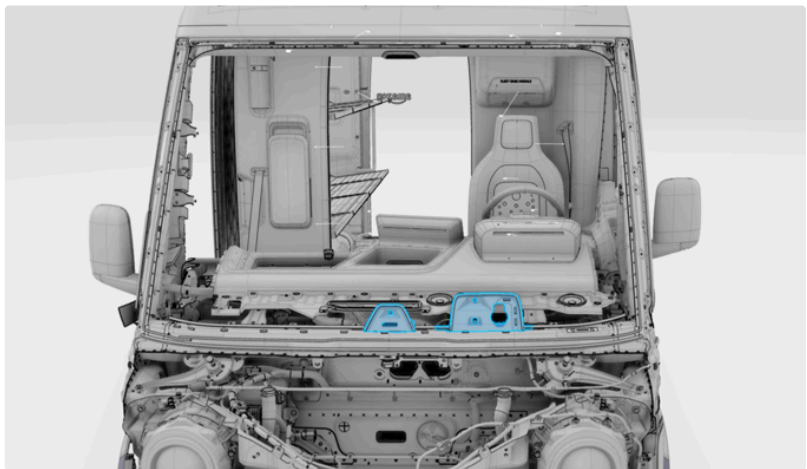

- Apply Urethane to the Body of the vehicle and make sure that all transitions are smooth, and all stop/go sections are connected to ensure a closed uniform bond path before installing the windshield.

- Once Urethane is applied to the vehicle body, you have approximately 8-12 min (depending on Temperature and Relative Humidity) to install the windshield onto the vehicle to ensure proper strength and a leak free replacement is met.

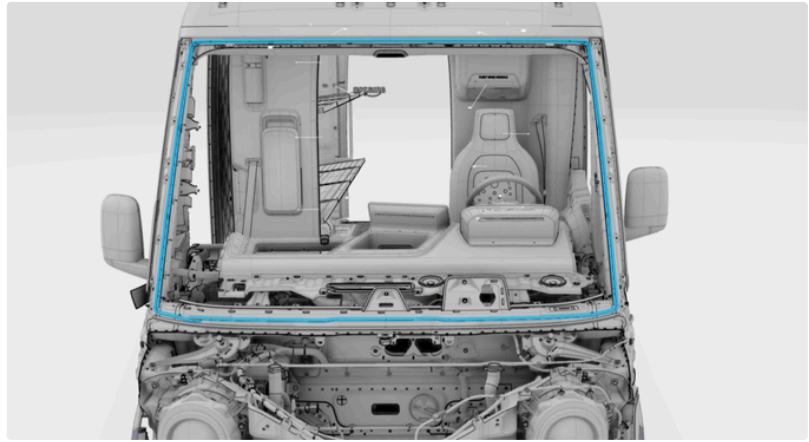

- With Equalizer Sentinel, Position the windshield for installation and guide it to the vehicle carefully. This may require additional support to properly guide into position.

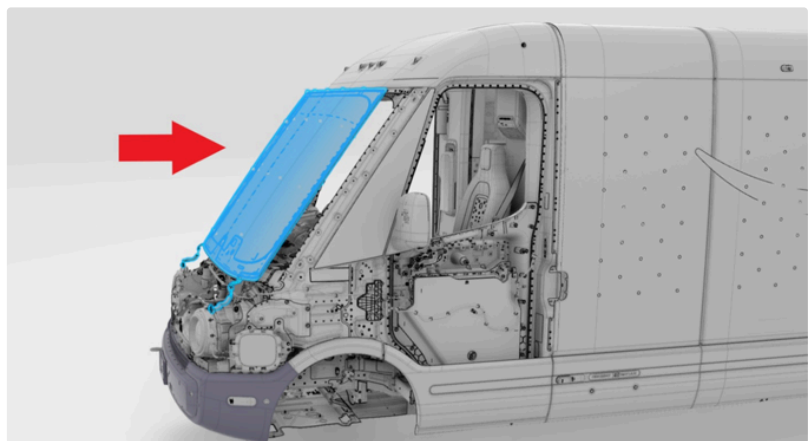

- During placement of the windshield with the Equalizer Sentinel tool, position the windshield and tilt it upwards to contact the upper dowel locators.
- This process may require additional support on both sides while one person operates the Equalizer Sentinel to ensure that the locator dowels are properly positioned.
- Once the top dowels have been positioned, tilt the windshield to install the bottom section onto the cowl. The locator pins will aid in setting the height and side to side placement of the windshield.
- If windshield is and R&I and there are no longer guide dowels, position glass to the original location as best as possible.

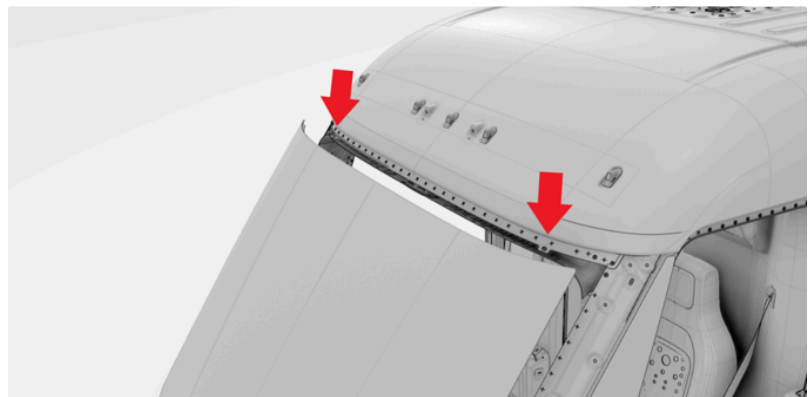

- Upon installation of the glass, apply tape (not limited to a specific amount) to the upper section of the windshield attaching it to the upper Header.
- This will aid in supporting the height of the windshield (especially if there are no locator dowels in which additional support may be needed at the base of the windshield during the curing process).

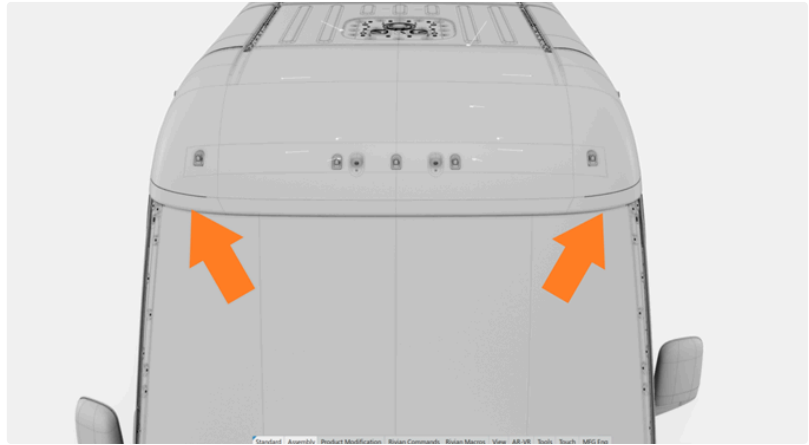

- Apply pressure with your hand to the highlighted surrounding areas to ensure proper contact and squeeze on the urethane is achieved.
- This aids in the bonding process and ensures that the sealing is tight.

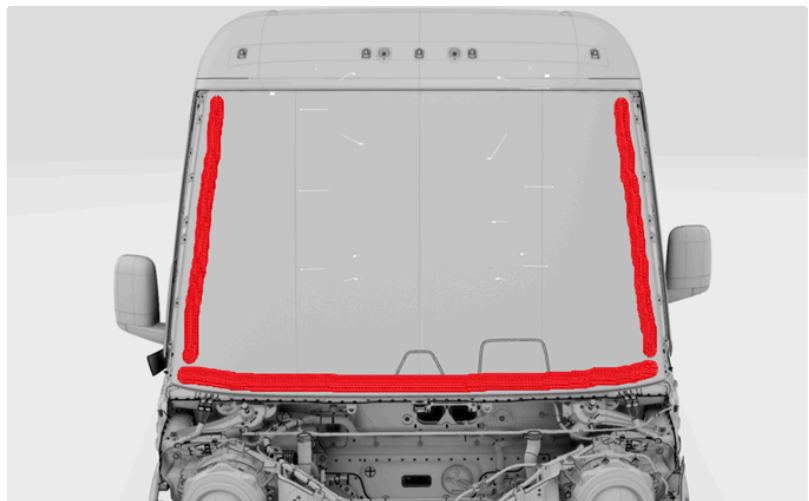

- On the interior of the vehicle with the windshield installed, attach a suction cup in the highlighted area and with medium effort, pull towards you to aid in putting pressure on the urethane.
- This will help with bonding and sealing in the top section of the windshield (pressure is not easily applied from the outside).

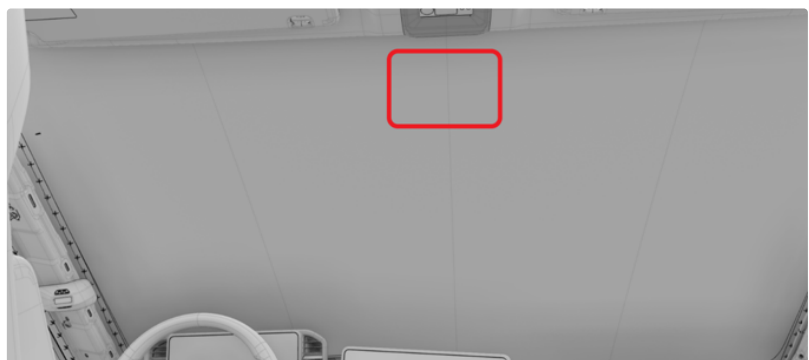

- Plug in the Rain Sensor Harness on windshield to the appropriate location.
- Fasten with bolts, the camera mounts to the vehicle
- Remove the cowl trim gutter guide (bottom of windshield on the outside)

across the entire bottom) on the new windshield before installing the Cowl trim.

- Install Interior trim in reverse order of removal
- Install exterior trim in reverse order of removal
- Perform necessary ADAS calibrations if needed

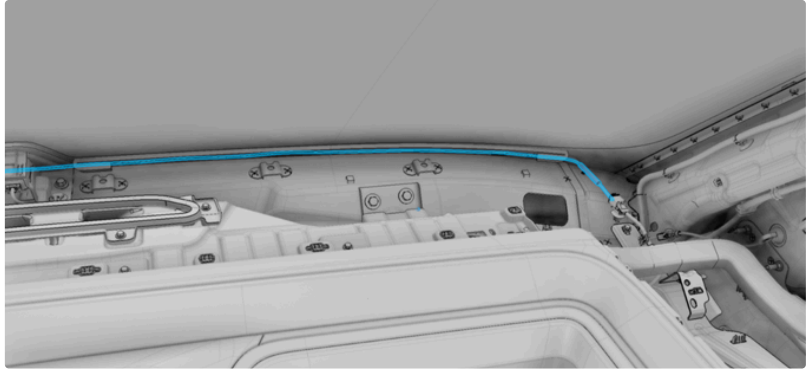

Video of tool validation installation (Ref only)



