

# NCT08109359: Tailgate Badge Jig, R1T

This tool is used to install **Badge, Model Designator, Rear** on R1T.

## Using the tool

**Note:**

Refer to the [Service Manual procedure](#) for additional information.

**Note:**

Do not remove the release liner or backing film until instructed to do so.

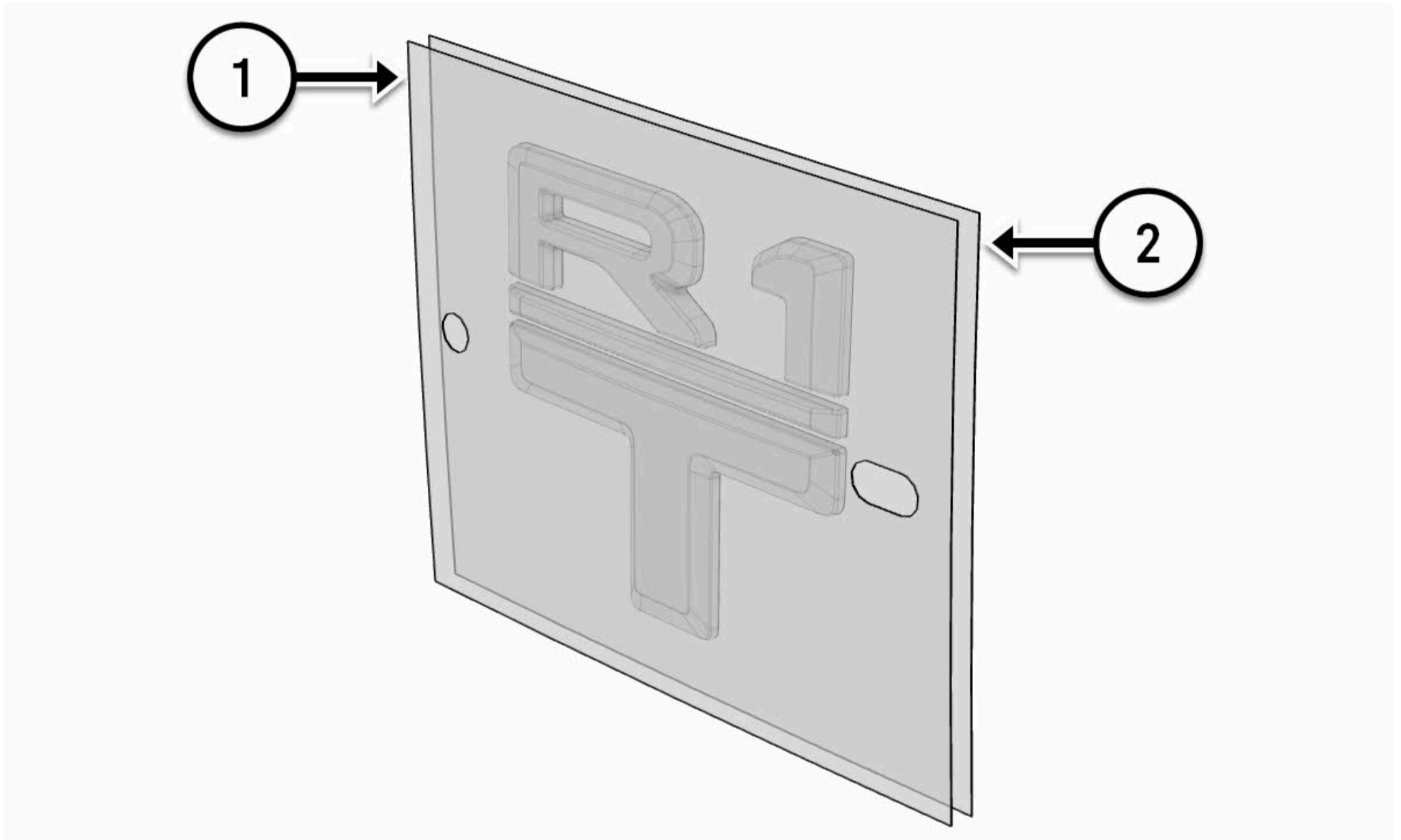

1	Release liner
2	Backing film

1. Position the tool as shown.



2. Apply tape.



3. Test-fit the component. Align the component to the locator post(s).



4. Remove the backing film from the adhesive material. Align the component to the locator post(s). Press firmly on the component for 30 seconds.

5. Remove the release liner and the tool.

