

TOOL USE INSTRUCTION

RIVIAN	TOOL NUMBER	TSN01509-300-B
	TITLE	ASCENT DRIVE UNIT BUSHING KIT
	REV - DATE	REV A - 10/01/2025

CONTENTS

[OVERVIEW](#)

[SAFETY](#)

[INITIAL SETUP](#)

[RDU TOOL USE INSTRUCTION](#)

[FDU TOOL USE INSTRUCTION](#)

[MAINTENANCE & STORAGE](#)

[SERVICE & REPLACEMENT PARTS](#)

[TROUBLESHOOTING](#)

[SYMBOL GLOSSARY](#)

TOOL FUNCTION

TO REMOVE AND INSTALL ASCENT FRONT AND REAR DRIVE UNIT BUSHINGS

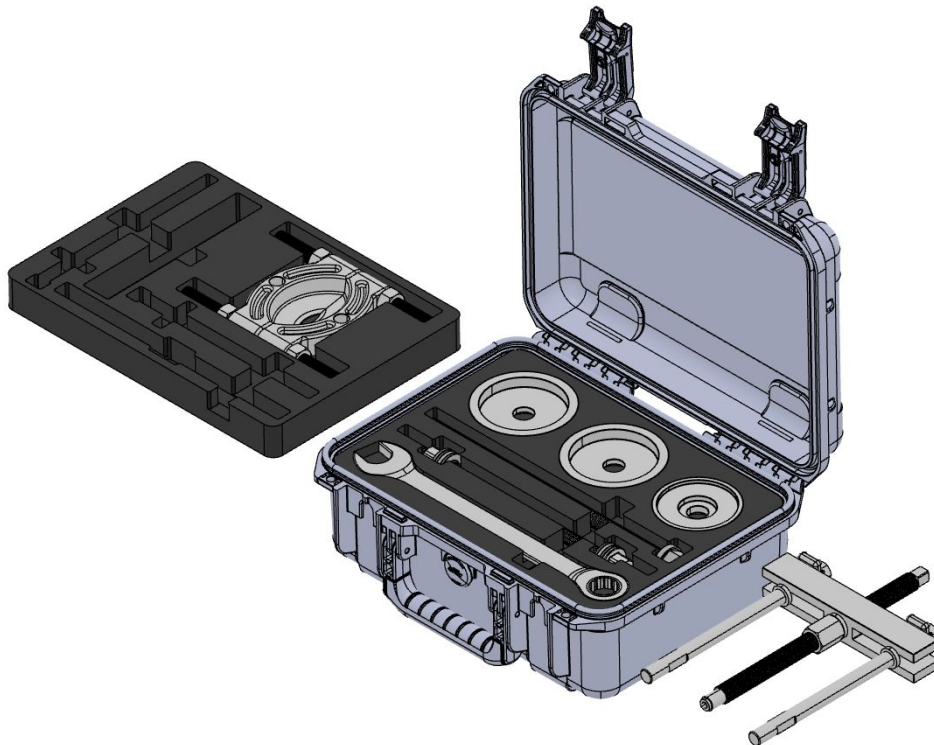

OVERVIEW

SPECIFICATIONS

Weight: 24 lbs

Overall Dimensions: 6-3/4 in.(H) x 13 in.(W) x 16-1/2 in.(L)

LABOR CODES

N/A

OTHER TOOLS REQUIRED

TSN00225-100-B: FLEX HEAD RATCHET WRENCH, 22MM

TSN00222-100-A: WRENCH, RATCHET BOX-END, FLEX HEAD, 22MM

TSN00897-100-B: 8" WIDE MOUTH ADJUSTABLE WRENCH (2X)

TSN00041-100-A: TORQUE WRENCH 3/8" DRIVE (20-100Nm)

TSN01113-100-A: 3/8" DRIVE METRIC 10 MM LONG BALL HEX SOCKET DRIVER

TSN01066-100-A: BALL-END HEX KEY SET



OVERVIEW

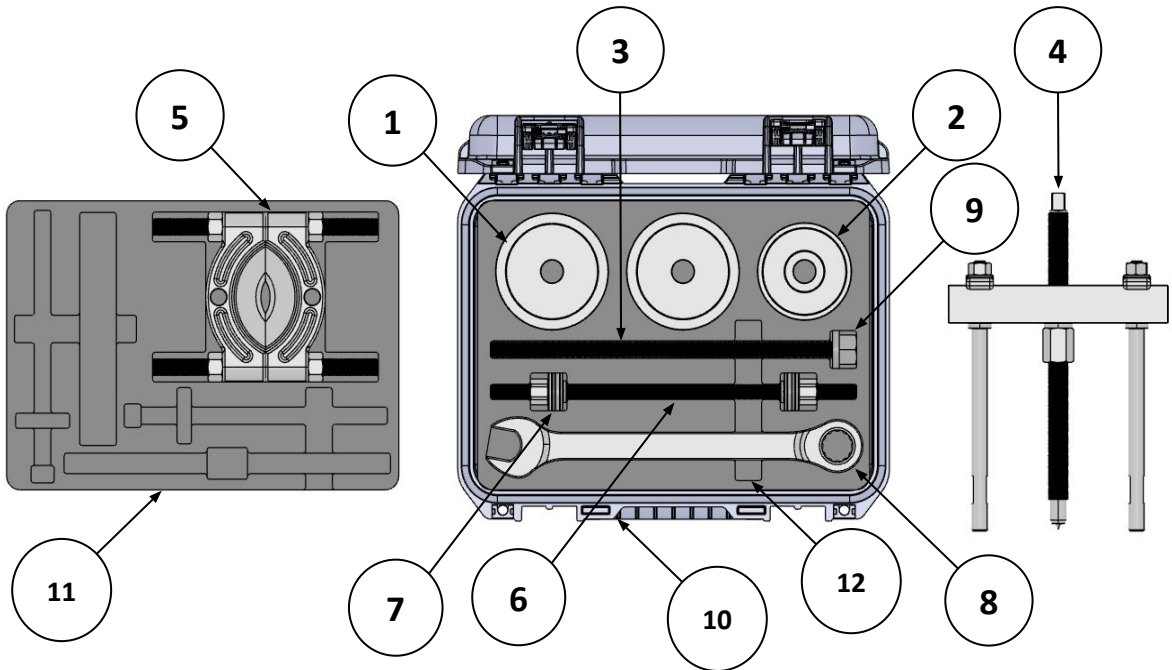

COMPONENT GUIDE

ITEM	QTY	NAME	TOOL P/N
1	2	BUSHING CUP 1	TSN01509-200-A
2	1	BUSHING CUP 2	TSN01509-201-A
3	1	M16 SPINDLE	TSN01509-202-A
4	1	PUSH-PULLER, 10-TON	TSN01575-100-A
5	1	BEARING SPLITTER	TSN01574-100-A
6	1	M14 SPINDLE	TSN01509-203-A
7	2	M14 NUT WITH BEARING	TSN01509-204-A
8	1	27MM RATCHETING WRENCH	TSN01576-100-A
9	1	M16 ROTATING FLANGE NUT	
10	1	PROTECTIVE CASE	
11	1	FOAM CUTOUT 1	
12	1	FOAM CUTOUT 2	







WARNING

Do not perform procedure if tool is damaged or missing parts. Consult the Rivian Service Tool Catalog for replacement components.

Failure to follow guidelines outlined in this document could result in injury and/or property damage.

SAFETY GUIDELINES

1	PPE Required - Eye Protection, Gloves, Closed Toe Shoes	
2	Risk of <ul style="list-style-type: none">• damage to vehicle or property if bushings aren't aligned properly	

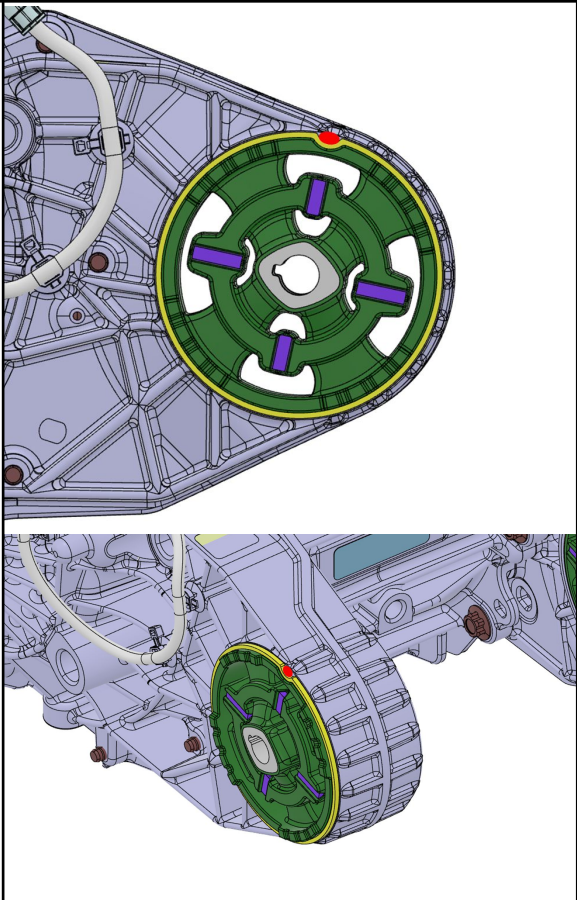

Step	Directions	Visual Aid
1	<p>Before removing the old bushings, use a Sharpie pen or equivalent to make a mark on the DU housing at the cutout on the bushing sleeve. See the red mark in the picture for reference.</p> <p>Do this for the bushing on both sides. This will be used as an alignment mark when installing the new bushings</p>	

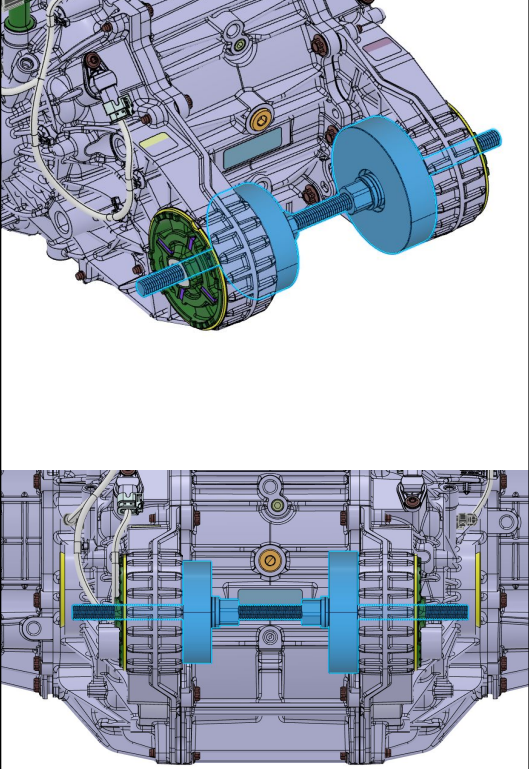
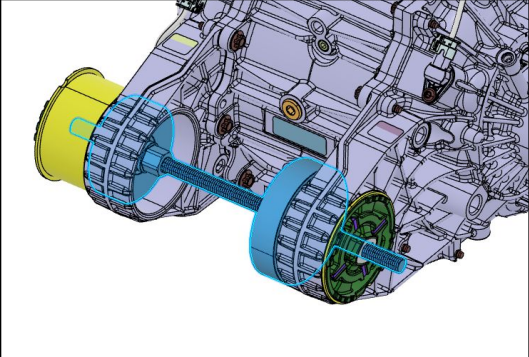

Step	Directions	Visual Aid
2	<p>For removal:</p> <p>Install items 1, 2, 6 and 7 as seen in the picture. The smaller cup (cup 2) will be used on the side that the bushing is to be pushed out. The larger cup (cup 1) will be on the opposite side.</p> <p>If using a ratcheting box end ratchet, the threaded rod can be inserted through the box end before the items are installed into place, so that the wrench is captured between the two cups.</p> <p><input type="checkbox"/> Remove and install one bushing at a time so that the other bushing can be used for alignment of the tool.</p>	 <p>The top diagram shows a side view of a mechanical assembly with two blue cups being positioned on opposite sides of a central shaft. The bottom diagram shows a top-down view of the same assembly with the cups and a threaded rod inserted through the center.</p>
3	<p>Use the wrench to turn either nut to drive out the bushing.</p>	 <p>The diagram shows a side view of the assembly with a wrench being applied to a nut on the threaded rod to drive out a bushing.</p>



Step	Directions	Visual Aid
4	<p>Use a Sharpie pen or equivalent to make a mark on the new bushing lined up with the cutout on the bushing sleeve. See the red mark in the picture for reference.</p> <p>There may also be a nub on the rubber bushing across from the cutout to be used for marking alignment.</p>	

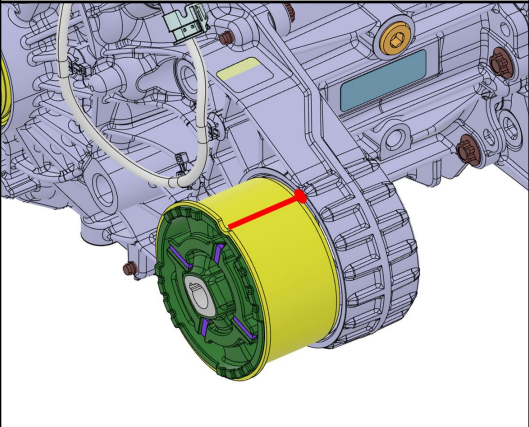
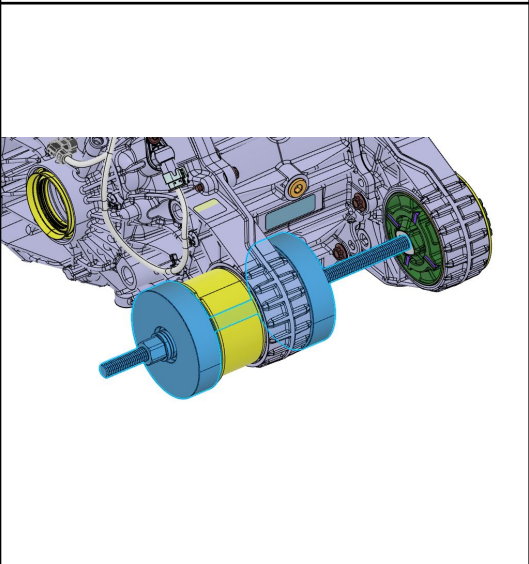

RDU TOOL USE INSTRUCTION

Step	Directions	Visual Aid
5	<p>Use this line to line up with the mark on the DU housing that was made in step 1.</p>	 A technical drawing of a DU housing assembly. A yellow cylindrical component is being positioned on a green gear-like base. A red arrow points from the top edge of the yellow component towards a mark on the housing, indicating the alignment line.
6	<p>For install:</p> <p>Install the items 1, 6 and 7 as seen in the picture. The larger cup (cup 1) will be used on both sides to drive the bushing in.</p> <p><input type="checkbox"/> Remove and install one bushing at a time so that the other bushing can be used for alignment of the tool.</p>	 A technical drawing showing the DU housing assembly with a blue bushing being inserted into a hole. A blue cup-shaped tool is used to press the bushing into the housing. The yellow cylindrical component from step 5 is also visible.

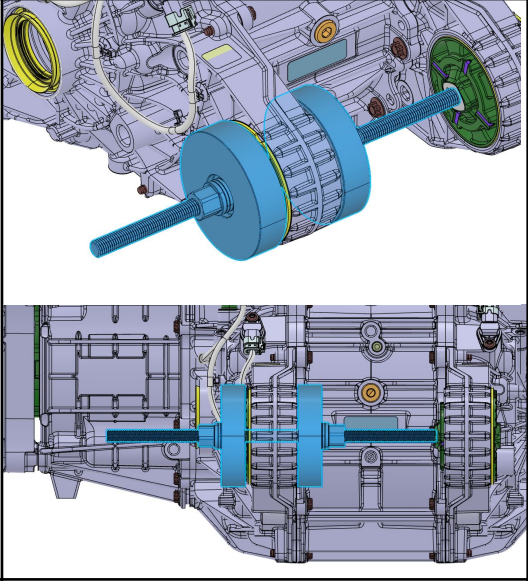

RDU TOOL USE INSTRUCTION

Step	Directions	Visual Aid
7	<p>Use the wrench to turn either nut to drive the bushing in until it seats flush against the DU housing.</p> <p>⚠ NOTE: Be sure to keep bushing straight while driving in. If the bushing begins to get uneven, stop and remove it and begin the installation again.</p>	
8	<p>Repeat steps 1-7 for the other bushing.</p>	

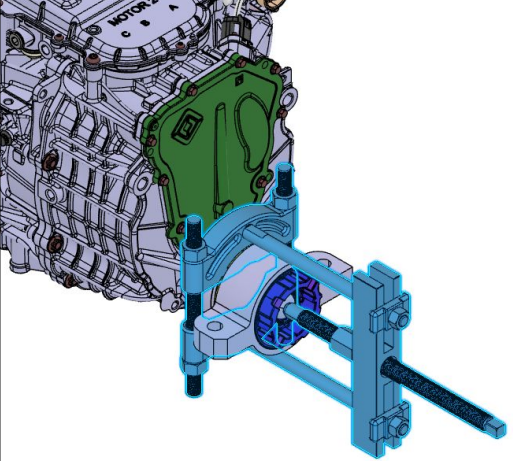
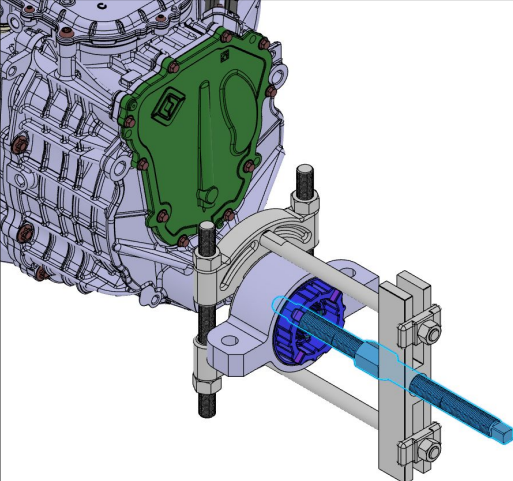

Step	Directions	Visual Aid
1	<p>For removal:</p> <p>Install items 4 and 5 as seen in the picture. The flat side of item 5 will be facing the bushing.</p>	
2	<p>Use one adjustable wrench on the 1" nut in the center to hold it in place while using the other adjustable wrench on the square end of the screw to rotate the screw to pull the mount off.</p>	

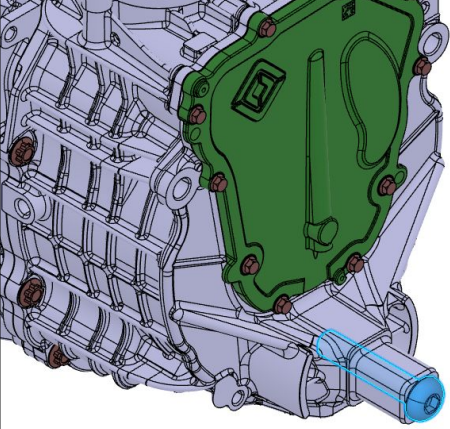
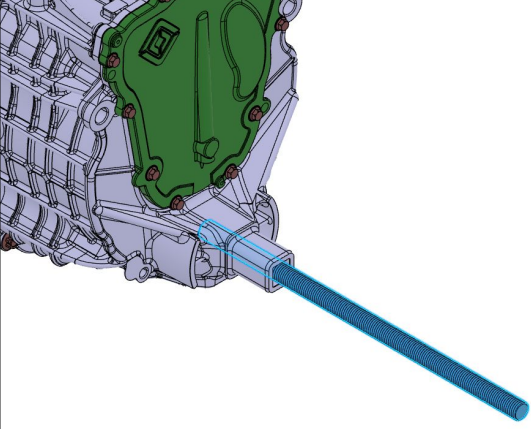
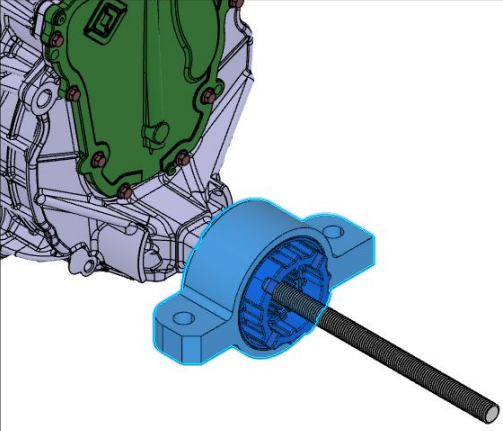

Step	Directions	Visual Aid
3	<p>For install:</p> <p>Remove the bolt using a 10mm hex key.</p>	
4	<p>Thread in item 3 by hand as far as it can go where the bolt was removed.</p>	
5	<p>Slide the new mount over item 3. Make sure the flanges are in the correct orientation.</p>	

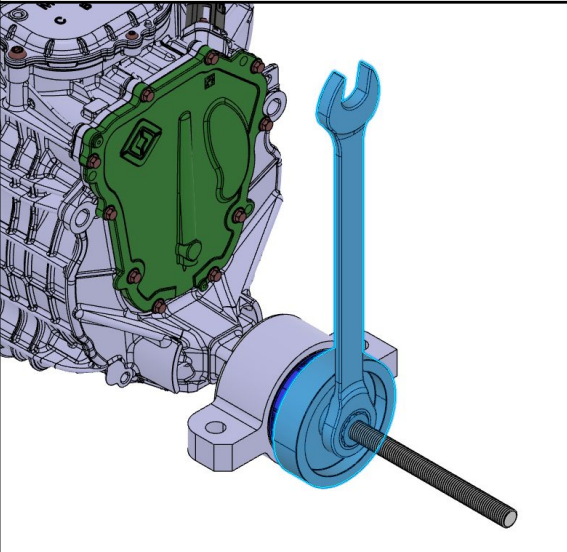
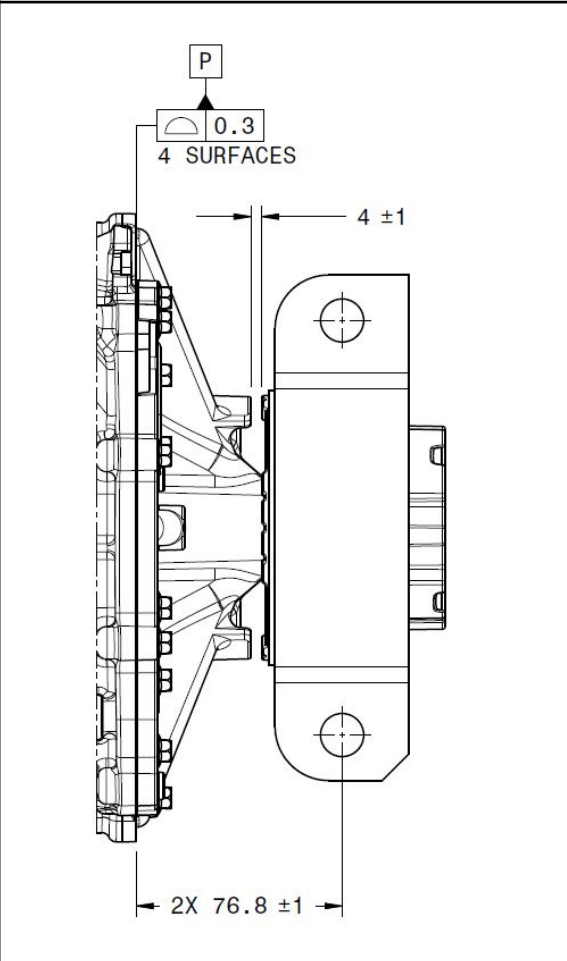

Step	Directions	Visual Aid
6	<p>Install items 1 and 9 as seen in the picture. The flat side of item 1 will be facing the bushing.</p> <p>Use item 8 to turn item 9 to drive the bushing on until it bottoms out.</p>	
7	<p>Make sure the gap is around 4 ± 2mm to avoid having issues with the DU to frame alignment.</p> <p>Production is 4 ± 1mm, but this may be hard to achieve due to springback.</p> <p>To alleviate springback, press the bushing all the way, let it settle for ~ 30 sec., back-up the tool, then press in again.</p>	

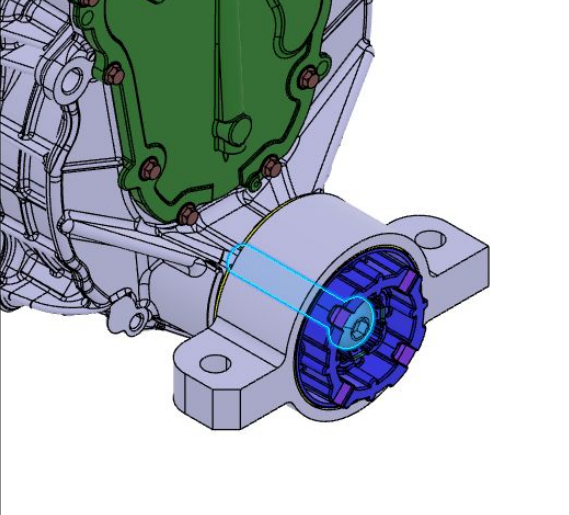

FDU TOOL USE INSTRUCTION

Step	Directions	Visual Aid
8	Remove the tooling and install the bolt and torque to 48 ± 10 Nm.	 A 3D CAD model of a mechanical assembly. The main body is light grey. A green component is mounted on top. A blue bolt is shown being installed into a hole on the side of the assembly. The bolt is highlighted in blue, and a blue line points to its location.



MAINTENANCE & STORAGE

Link Here (If applicable) to Tooling Maintenance Guide (TMG)

BASIC MAINTENANCE GUIDE

TASK	FREQUENCY
Verify all components are accounted for	Before and after every use
Inspect all threads for damage	Before and after every use



SERVICE & REPLACEMENT COMPONENTS

FOR OTHER ITEMS NOT SHOWN, CONTACT RIVIAN SERVICE TOOL ENGINEERING

ITEM	DESCRIPTION	SUPPLIER + PART NUMBER
1	M16 ROTATING FLANGE NUT	MCMaster-CARR #90477A124
2	27MM RATCHETING WRENCH	MCMaster-CARR #5163A93
3	PROTECTIVE CASE	HARBOR FREIGHT #63927
4	M14 NUT WITH BEARING	MUELLER-KUEPS #609 400/D14
5	M14 SPINDLE	MUELLER-KUEPS #609 400/S14
6	BEARING SPLITTER	OTC #1123
7	PUSH-PULLER, 10-TON	OTC #927

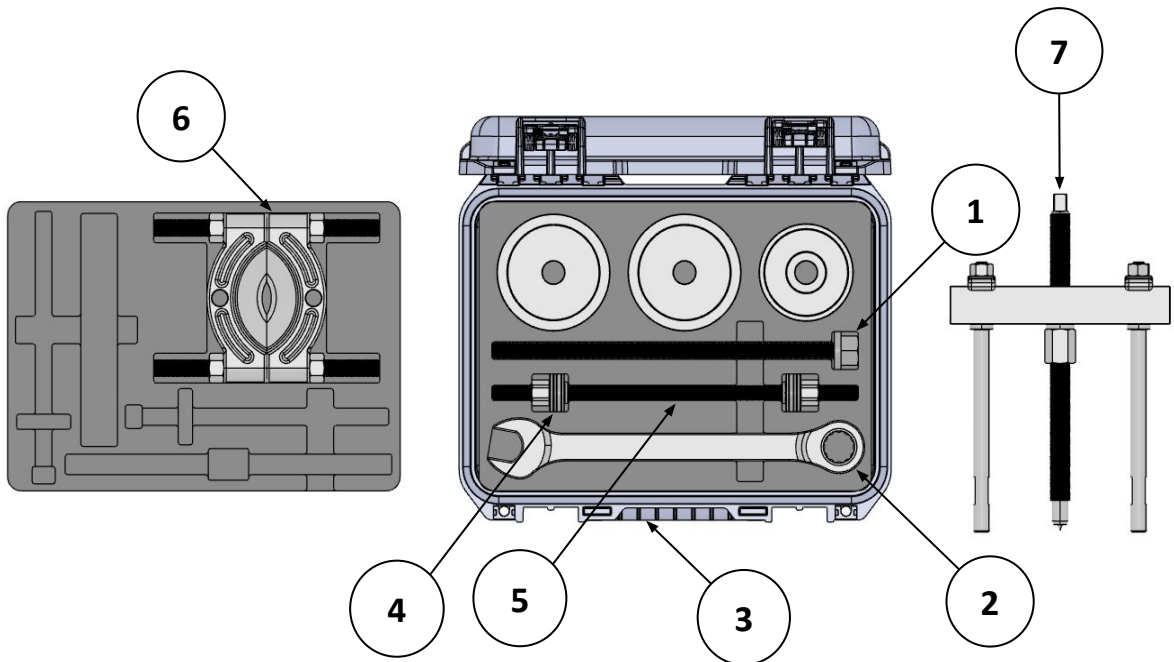

TROUBLESHOOTING

PROBLEM	SOLUTION
The bushing begins to get uneven during install.	Stop and remove it and begin the installation again.





DANGER

Risk of electrocution or electric shock



WARNING

Risk of minor injury



DANGER

Risk of major injury such as

- fire
- chemical or poison
- crushing / maiming
- death



CAUTION

Risk of

- damage to vehicle or property
- data disruption
- voiding warranty

IMPORTANT

Instructions to successfully complete a task

NOTE

Useful information

REVISION LOG

REV	DATE	CHANGE DESCRIPTION
A	10/01/2025	Initial release

