

TOOL USE INSTRUCTION

RIVIAN

TOOL NUMBER

TSN01642-300

TITLE

HV BATTERY GUIDE PIN KIT - R2

REV - DATE

REV 01 - 3/4/2026

CONTENTS

[OVERVIEW](#)

[SAFETY](#)

[INITIAL SETUP](#)

[BATTERY REMOVAL](#)

[BATTERY REPLACEMENT](#)

[BATTERY INSTALL](#)

[MAINTENANCE & STORAGE](#)

[TROUBLESHOOTING, SYMBOL GLOSSARY](#)

TOOL FUNCTION

USED TO ALIGN THE R2 HV BATTERY TO THE BODY DURING INSTALLATION



SPECIFICATIONS

Manufacturer PN: NCT27590089
Flange Pin Diameter: 22mm
Treehouse Pin Diameter: 14.3 mm (9/16")

LABOR CODES

301010010 HV Battery (Remove and Replace)
301010011 HV Battery (Remove and Reinstall)

OTHER TOOLS REQUIRED

TSN00486-100 - BATTERY LIFT TABLE
[TSN00553-300](#) - BATTERY LIFT TABLE JIG
[TSN00541-300](#) - BATTERY LIFT SPREADER BEAM

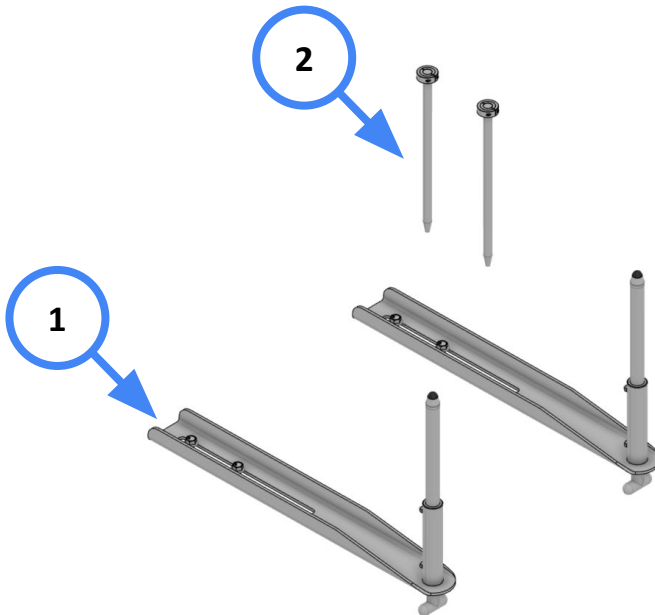

TOOL KIT CONTENTS

ITEM	QTY	RIVIAN TOOL ID	DESCRIPTION
1	2	TSN01642-200-A	FLANGE GUIDE PIN
2	2	TSN01642-201-A	POWERHOUSE GUIDE PIN





**WARNING**

Do not perform procedure if tool is damaged or missing parts. Consult the Rivian Service Tool Catalog for replacement components.

Failure to follow guidelines outlined in this document could result in injury and/or property damage.



SAFETY GUIDELINES

1	Inspect and replace worn or damaged components as needed	
2	Tool is intended to be used only as described in these instructions.	
3	<p>Be cautious of areas where body parts or clothing could get caught or crushed between moving parts of the equipment, potentially causing serious injury.</p> <p>Use spotters and communicate whenever raising or lowering lift table to ensure all pinch points are clear of personnel or objects.</p>	

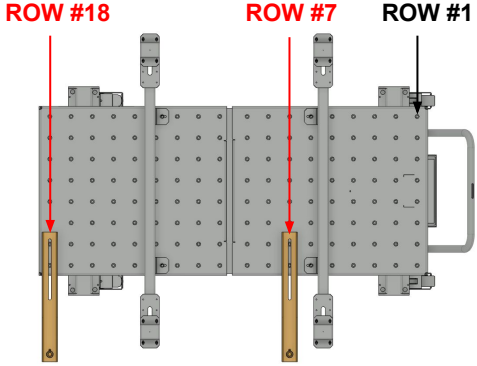
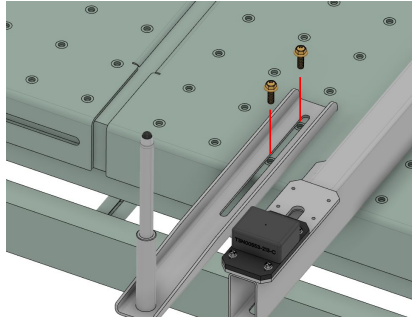
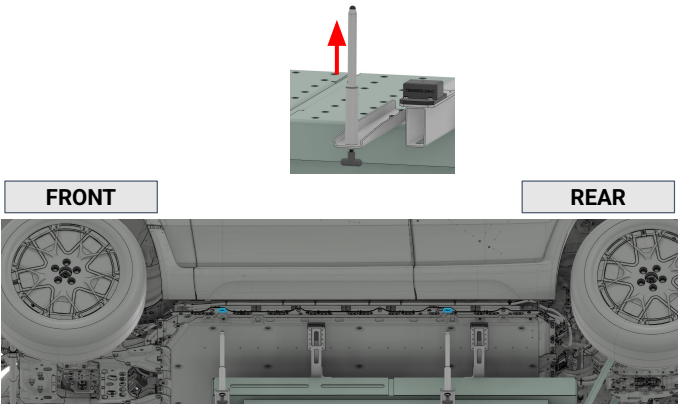
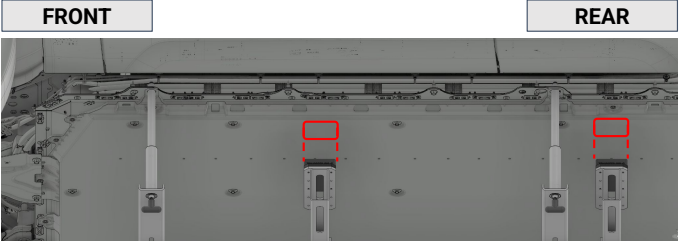

<p>1</p>	<p>Place Flange Guide Pins (TSN01642-200) on the battery lift table (TSN00486-100) at hole positions shown.</p> <p>Note placement of jigs relative to the lift table handle and TSN00553-300 lift table jigs.</p>	
<p>2</p>	<p>Secure each pin bracket with 2X fasteners at the designated lift table holes.</p> <p>Keep fasteners loose for initial pin alignment.</p>	
<p>3</p>	<p>Use the T-handle to extend both guide pins to the uppermost position.</p> <p>Raise the lift table until pins engage with the 2X alignment holes on the pack and vehicle body.</p>	
<p>4</p>	<p>Adjust table position until the 4X support pads on the lift table jig are properly centered on the pack – see TSN00553-300 tool use instructions for details.</p> <p>Tighten 4X fasteners until snug to secure the guide pin brackets to the lift table.</p>	

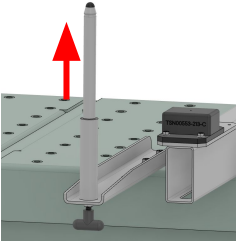

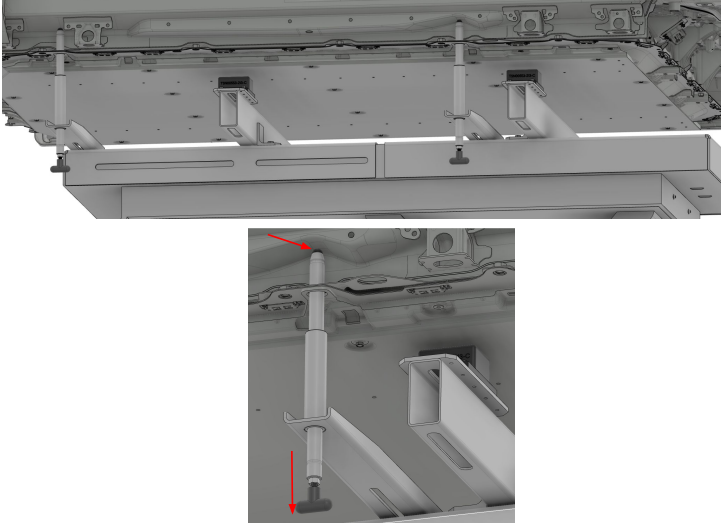
<p>1</p>	<p>Fully extend the flange guide pins to the uppermost position.</p> <p>Note that guide pins will “click” into place at the top and bottom limits of travel.</p>	
<p>2</p>	<p>Raise the lift table until guide pins engage with the 2x locating holes on the LH side of the vehicle.</p>	
<p>3</p>	<p>Once both pins are located to the vehicle, continue to raise the table until 4X lift table pads are approx. 1” from the bottom of the pack.</p> <p>NOTE</p> <p>Rubber tip on the guide pins is intended to contact the vehicle.</p> <p>Pins will retract downward as table is lifted into place.</p>	
<p>4</p>	<p>Level the lift table as needed until all 4X pads are evenly spaced from the pack.</p> <p>Continue to raise the lift table until at least 3X pads are fully contacting the pack, then STOP.</p>	
<p>5</p>	<p>Refer to service manual procedure for remaining HV battery removal steps.</p>	

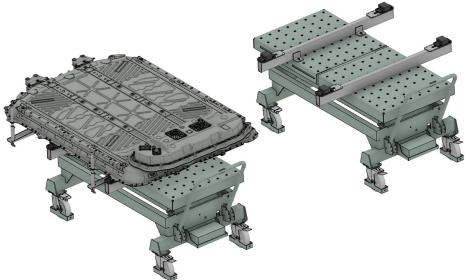
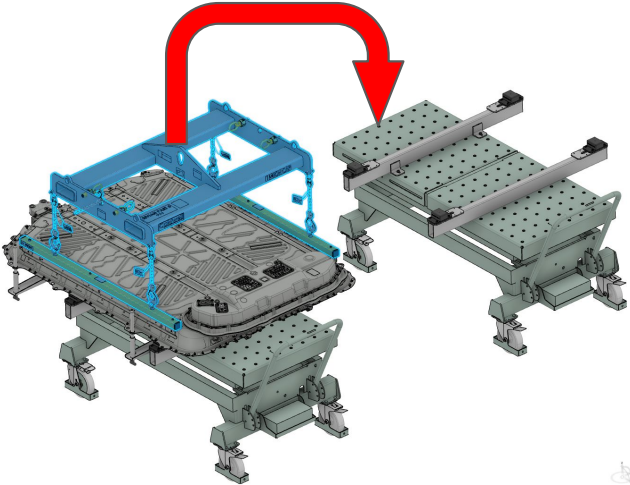
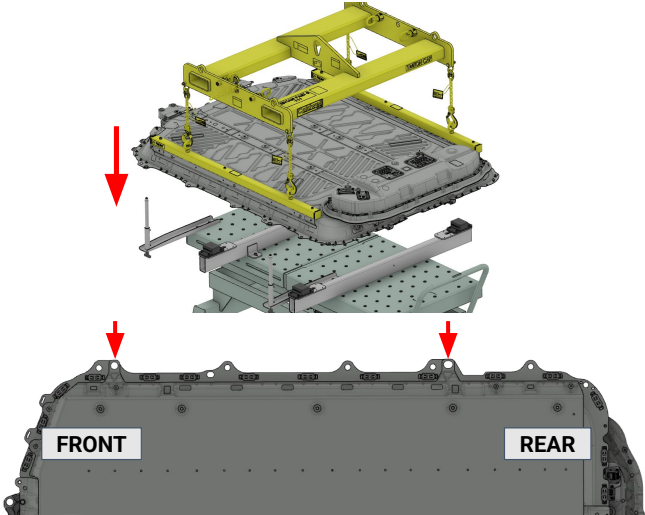

<p>1</p>	<p>For battery remove and <u>reinstall</u>:</p> <p>Proceed to BATTERY INSTALL</p> <p>For battery remove and <u>replace</u>:</p> <p>Position a 2nd battery table next to the lift table used to remove the pack from the vehicle.</p>	
<p>2</p>	<p>Use TSN00541-300 - BATTERY LIFT SPREADER BEAM to lift the pack from the table.</p> <p>Transfer the pack to the 2nd lift table, ensuring pack is well supported by all 4X rubber lift table pads.</p> <div style="border: 1px solid black; border-radius: 15px; padding: 10px; margin-top: 10px;"> <p>IMPORTANT</p> <p>Confirm that guide pin brackets are fastened to the lift table before removing pack from the table. This ensures pack-to-table position is maintained.</p> </div>	
<p>3</p>	<p>Attach spreader beam to the new replacement pack and lift out of the shipping crate.</p> <p>Lower the new pack onto the lift table, ensuring guide pins are engaged with the 2x locating holes on the LH side of the pack.</p>	
<p>4</p>	<p>Transfer the old pack from the 2nd lift table into the shipping crate.</p>	

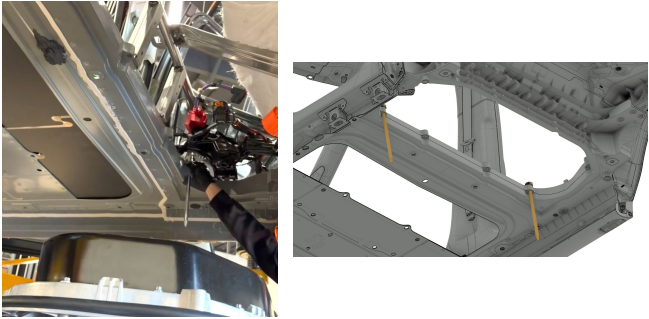
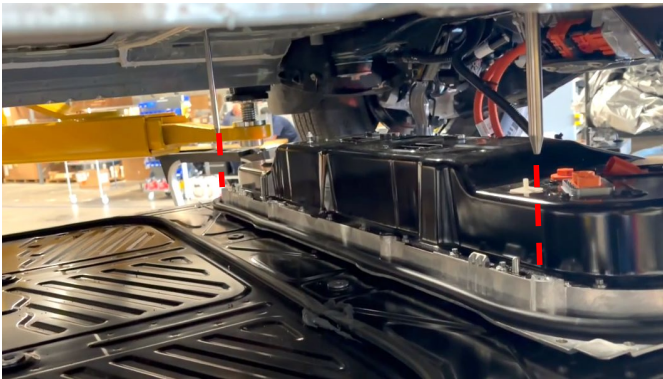
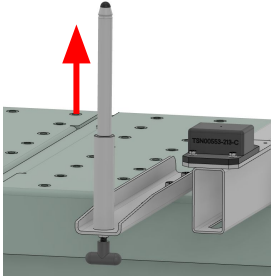
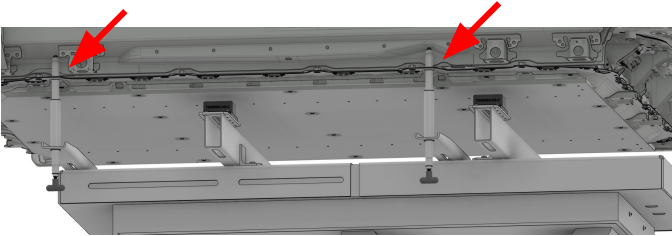

<p>1</p>	<p>With the vehicle lifted, reach from under the rear seat opening to install 2X Powerhouse Guide Pins (TSN01642-201-A) in location shown, tapered end pointed downward.</p>	
<p>2</p>	<p>Raise the pack to the vehicle, visually aligning the 2x Powerhouse Guide Pins to the fastener holes at the front of the powerhouse as shown.</p>	
<p>3</p>	<p>Fully extend the Flange Guide Pins to the upper-most position. Note that guide pins will “click” into place at the top and bottom limits of travel.</p>	
<p>4</p>	<p>Once Powerhouse Guide Pins located to the pack fastener holes, continue to raise the pack until the Flange Guide Pins are engaged with the vehicle.</p>	
<p>5</p>	<p>Refer to TSN00553-300 tool use instructions and service manual procedure for remaining re-installation steps.</p>	



BASIC MAINTENANCE GUIDE

TASK	FREQUENCY
Visually inspect pins, rubber bumpers, and other critical surfaces for signs of wear or damage. Replace components as needed.	Before Each Use
Store indoors in a dry environment.	After Each Use

SPARE PARTS

FOR OTHER ITEMS NOT SHOWN, CONTACT RIVIAN SERVICE TOOL ENGINEERING

ITEM	DESCRIPTION	SUPPLIER	PART NUMBER
1	M10 FLANGE HEAD BOLT	MCMaster-CARR	94036A631
2	BUMPER		9541K81
3	T-HANDLE		65035K48
4	O-RING SIZE 118		9452K82
5	SHAFT COLLAR		6435K54

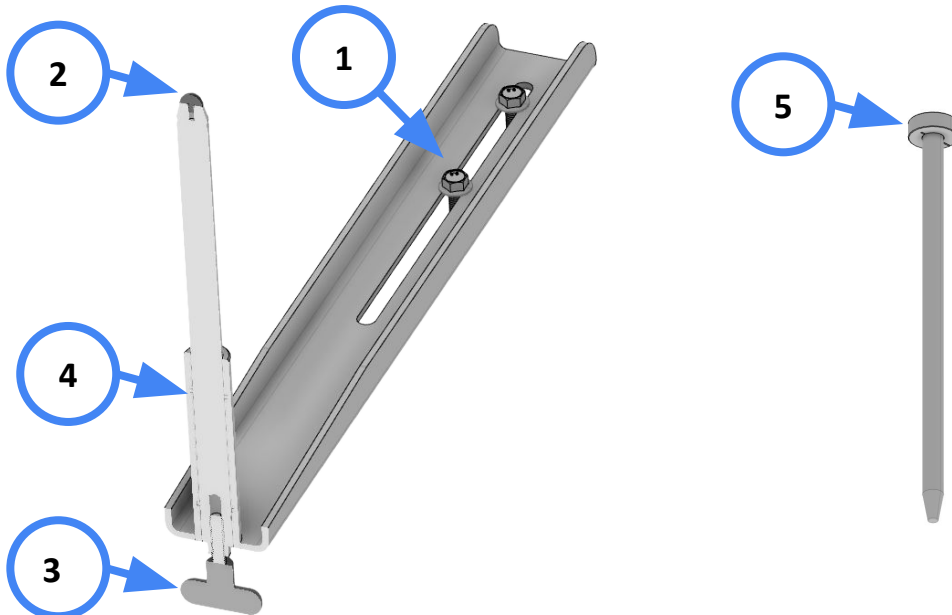

PROBLEM	SOLUTION
<p>Flange guide pins not retracting / sticking while raising and lowering the table.</p>	<p>Remove guide pin from the sleeve by pulling downward on the T-handle.</p> <p>Inspect sleeve ID and seals for signs of debris or damage.</p> <p>Clean/replace seals as needed and apply light coating of Superlube or similar o-ring grease before reassembly</p> <p>See SPARE PARTS</p>
<p>Flange guide pins do not stay in place, retract downward under their own weight.</p>	<p>Wipe away any excess grease or oil at the pin / sleeve interface.</p> <p>Seals on the sleeve ID be worn - inspect and replace as needed.</p> <p>See SPARE PARTS</p>

SYMBOL GLOSSARY



WARNING

Risk of minor injury

IMPORTANT

Instructions to successfully complete a task



CAUTION

Risk of Pinch Point

NOTE

Useful information

REV	DATE	CHANGE DESCRIPTION
1	03/04/2026	Initial release

