

TOOL USE INSTRUCTION

RIVIAN	TOOL NUMBER	TSN01675-300
	TITLE	R2 LIFTGAGE EMBLEM JIG, "R2"
	REV - DATE	REV 1 - 02/16/2026

CONTENTS

[OVERVIEW](#)

[SAFETY](#)

[INITIAL SETUP](#)

[TOOL USE INSTRUCTION](#)

[MAINTENANCE & STORAGE](#)

[TROUBLESHOOTING](#)

[SYMBOL GLOSSARY](#)

TOOL FUNCTION

INSTALLING THE "R2" BADGE ON THE LIFTGATE OF R2

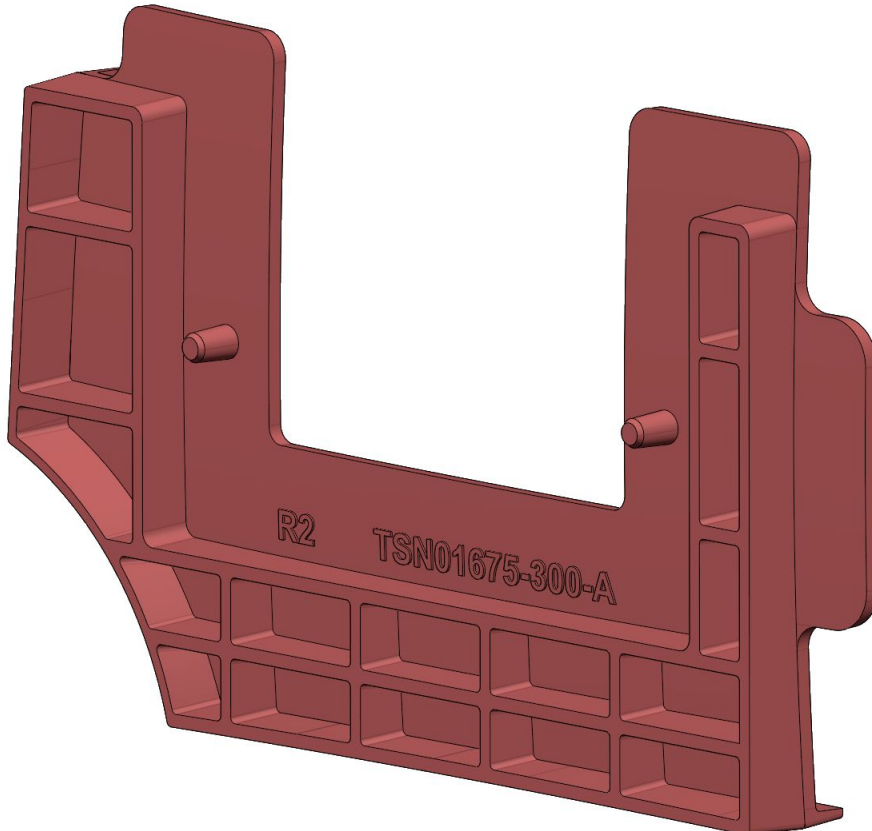

OVERVIEW

LABOR CODES

608799227: Badging Decals and Labels Other Labor

ADDITIONAL TOOLS

- TSN00720-100-A: Emblem and Molding Roller
- IPA wipes or equivalent surface cleaning method
- metric tape measure
- Masking tape

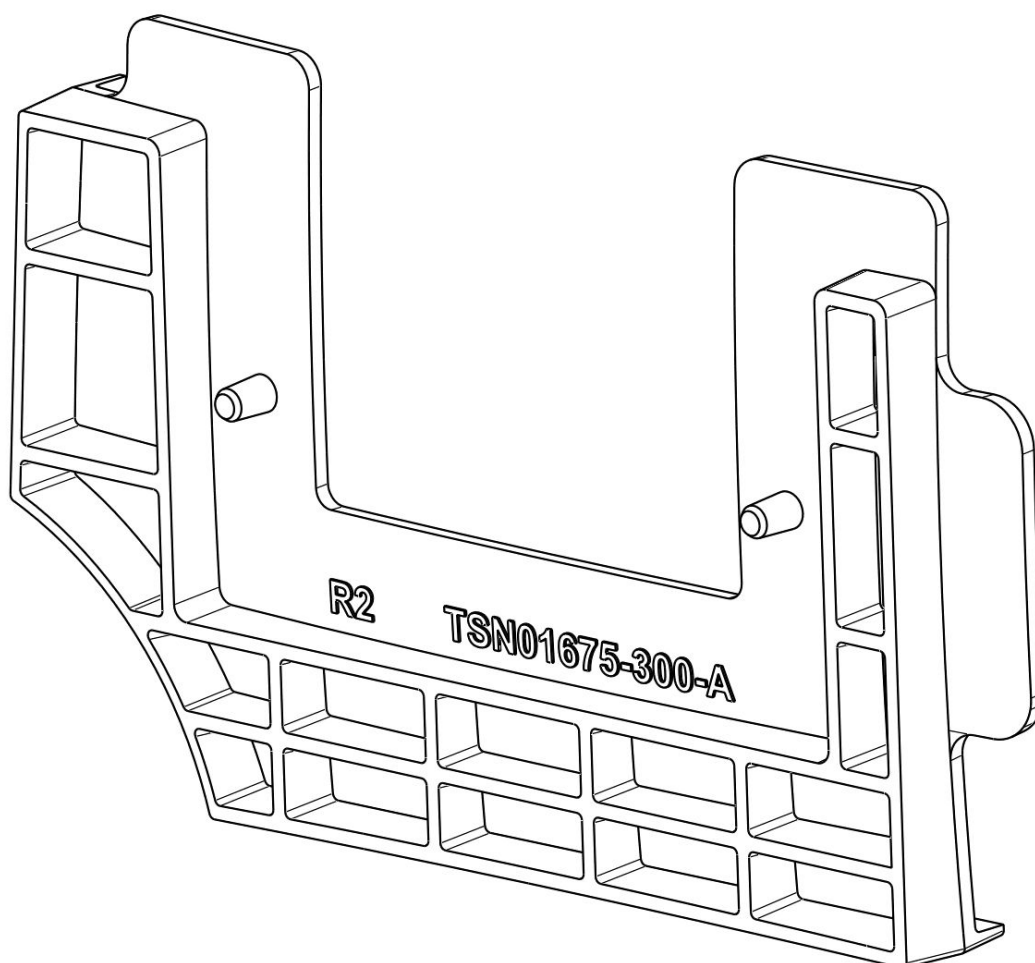



WARNING

Do not perform procedure if tool is damaged or missing parts. Consult the Rivian Service Tool Catalog for replacement components.

Failure to follow guidelines outlined in this document could result in injury and/or property damage.

SAFETY GUIDELINES

1	<p style="text-align: center;">PPE REQUIRED</p> <ul style="list-style-type: none">• Latex or Nitrile Gloves	
---	--	---

INITIAL SETUP

1

Clean the badge jig and the application area using isopropyl alcohol wipes or rubbing alcohol on a clean cloth.

Allow the surface to fully dry before installing badge.

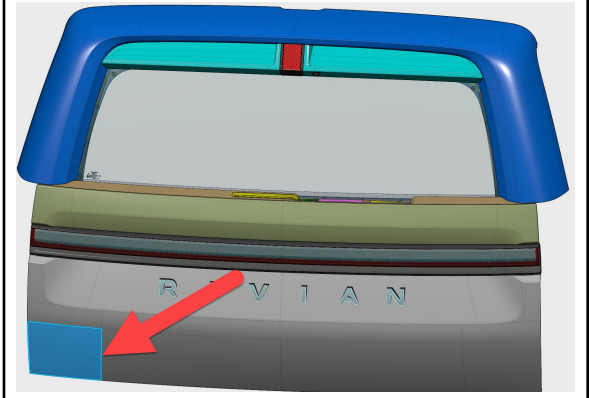

TOOL USE INSTRUCTION

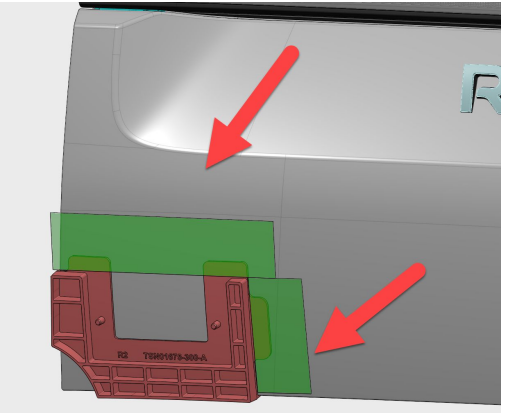
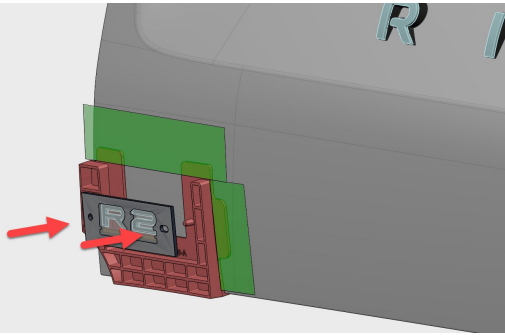
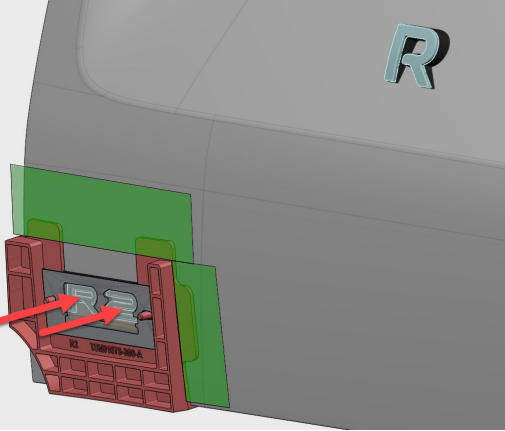
<p>1</p>	<p>Using masking tape, adhere the badge jig to the lower right hand corner of the tailgate.</p> <p>Ensure the edges of the jig fully contact the side and bottom edges of the tail gate.</p>	
<p>2</p>	<p>Remove the backer from the badge and carefully place it into the locating space using the pins and alignment holes in the film/foam carrier as a guide.</p>	
<p>3</p>	<p>Apply pressure with a roller for 30 seconds to ensure badge is fully attached.</p>	



BASIC MAINTENANCE GUIDE

TASK	FREQUENCY
Ensure the badge jig is clean and free of oils and debris that may damage paint	Before Each Use
Visually inspect badge jig for wear or damage	Before Each Use
Return badge jig to the special tools area. Do not place anything on the jig to prevent deformation.	After Each Use



TROUBLESHOOTING

PROBLEM	SOLUTION
Badge jig does not fit the contours of the vehicle.	Make sure you are using the badge jig designated for the correct vehicle and there is no warpage or damage to the jig.
Badge jig does not fit	Make sure there is no debris or damage on the the jig.





DANGER

Risk of electrocution or electric shock



WARNING

Risk of minor injury



DANGER

Risk of major injury such as

- fire
- chemical or poison
- crushing / maiming
- death



CAUTION

Risk of

- damage to vehicle or property
- data disruption
- voiding warranty



CAUTION

Risk of Pinch Point

- keep hands and fingers clear of all moving parts.



PPE REQUIRED

IMPORTANT

Instructions to successfully complete a task

NOTE

Useful information

REVISION LOG

REV	DATE	CHANGE DESCRIPTION
1	02/16/26	Initial release

