

TOOL USE INSTRUCTION

RIVIAN

TOOL NUMBER TSN01683-300

TITLE FRONT HUB SUPPORT TOOL

REV - DATE REV 1 - 5/13/2026

CONTENTS

[OVERVIEW](#)

[SAFETY](#)

[INITIAL SETUP](#)

[TOOL USE INSTRUCTION](#)

[MAINTENANCE & STORAGE](#)

[TROUBLESHOOTING](#)

[SYMBOL GLOSSARY](#)

TOOL FUNCTION

SUPPORT R2 FRONT SUSPENSION DURING SUBFRAME REMOVAL

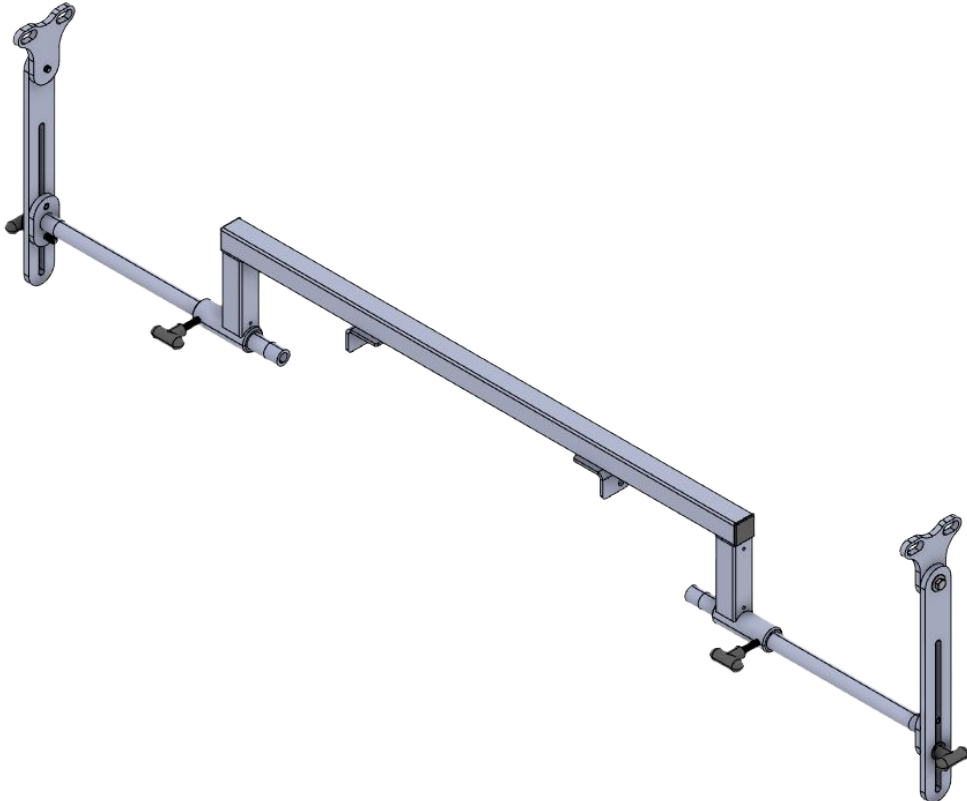

5/13/2026 REV 1

Printed or Downloaded Files are Uncontrolled, For Reference Only

OVERVIEW

SPECIFICATIONS

Weight: 12.251Kg

Overall Dimensions: 1740mm x 448mm x 108mm

LABOR CODES

4655 - SUBFRAMES (ALL SUB LABOR CODES)

OTHER TOOLS REQUIRED

TSN00897-100-B 8" WIDE MOUTH ADJUSTABLE WRENCH

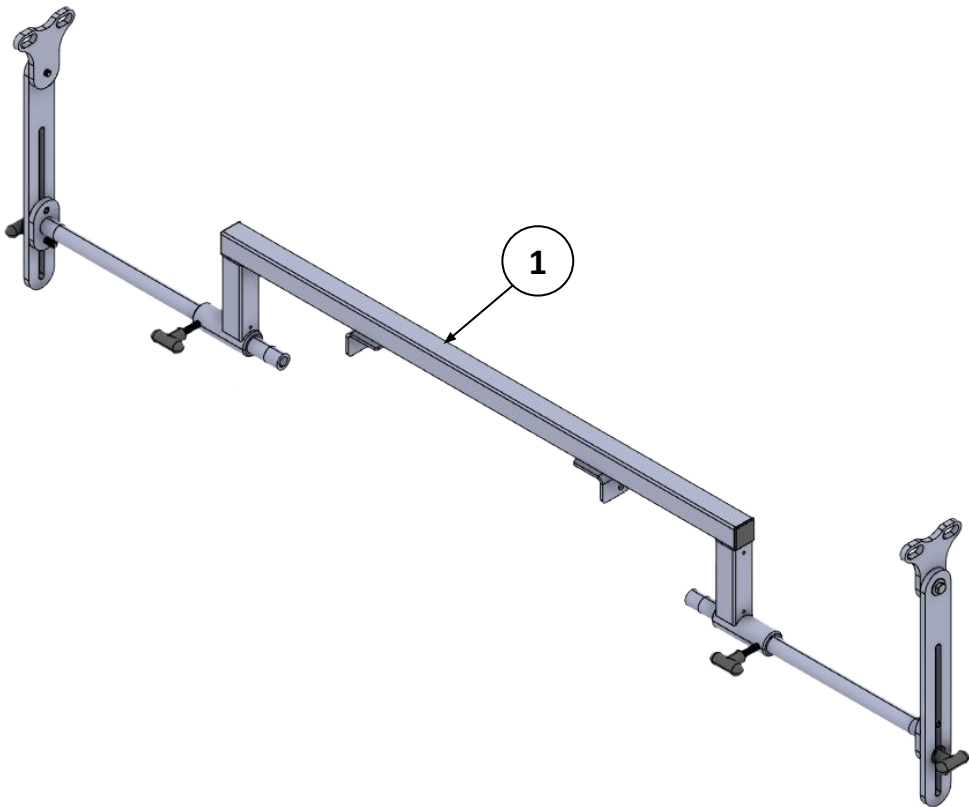

COMPONENT GUIDE

| ITEM | QTY | TOOL P/N | DESCRIPTION |
|------|-----|--------------|------------------------|
| 1 | 1 | TSN01683-300 | FRONT HUB SUPPORT TOOL |







WARNING

Do not perform procedure if tool is damaged or missing parts. Consult the Rivian Service Tool Catalog for replacement components.

Failure to follow guidelines outlined in this document could result in injury and/or property damage.

SAFETY GUIDELINES

| | | |
|---|---|---|
| 1 | Risk of damage to vehicle or property. | |
| 2 | Risk of Pinch Point <ul style="list-style-type: none">• keep hands and fingers clear of all moving parts. |  |
| 3 | PPE REQUIRED <ul style="list-style-type: none">• eye protection• closed toe shoes• gloves |  |

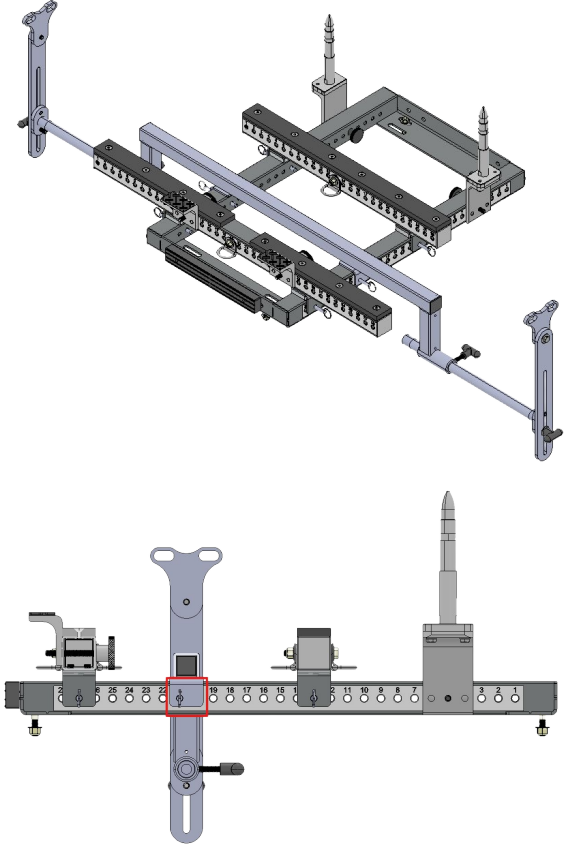
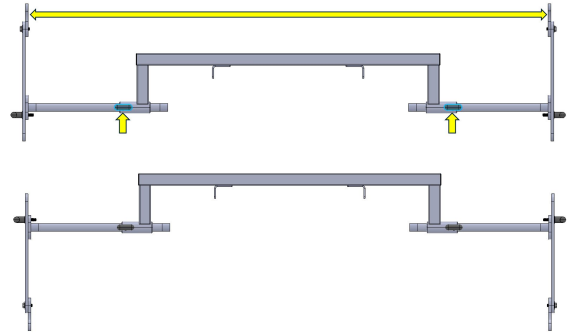

TOOL USE INSTRUCTION

| | | |
|----------|--|--|
| <p>1</p> | <p>Install the FRONT HUB SUPPORT TOOL to SUBFRAME SUPPORT JIG in locations shown, hole #21. Tighten the grip knob until fully seated and snug.</p> <p>⚠ NOTE: Make sure the mounting bracket is oriented with the offset hole facing the correct direction.</p> |  |
| <p>2</p> | <p>Use the adjustment knobs and move the hubs support arms so that the FRONT HUB SUPPORT TOOL is wider than the span of the wheel studs or they are oriented downward.</p> |  |
| <p>3</p> | <p>Follow the steps in TUI_TSN00542-206-A: FRONT SUBFRAME ALIGNMENT PIN - R2 to raise the SUBFRAME SUPPORT JIG up to the vehicle.</p> | |

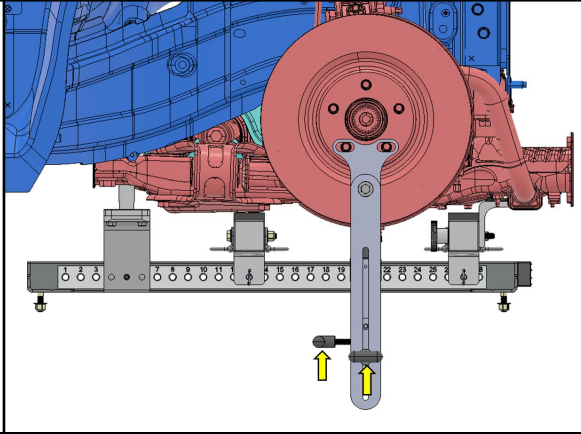
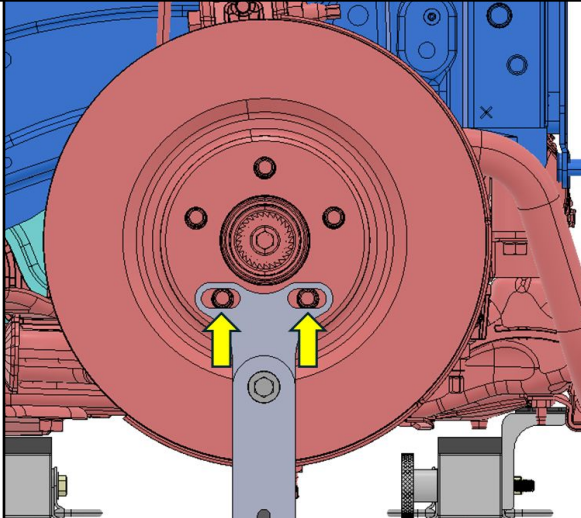

TOOL USE INSTRUCTION

| | | |
|---|--|---|
| 4 | <p>Once the SUBFRAME SUPPORT JIG is fully seated against the underbody, move the hub support arms up and over the wheel studs and tighten the adjustment knobs to lock the FRONT HUB SUPPORT TOOL into position.</p> |  |
| 5 | <p>Install lugnuts onto the two wheel studs that are inserted through the hub support arms.</p> |  |
| 6 | <p>Follow the steps in TUI_TSN00542-206-A: FRONT SUBFRAME ALIGNMENT PIN - R2 to remove the subframe from the vehicle.</p> | |







BASIC MAINTENANCE GUIDE

| TASK | FREQUENCY |
|--|---------------------------|
| Visually inspect for bent/damaged components. | Before Each Use |
| Wipe away excess dirt and debris using a clean shop rag. | Before and After Each Use |

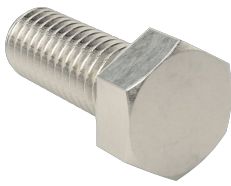

SERVICE & REPLACEMENT COMPONENTS

FOR OTHER ITEMS NOT SHOWN, CONTACT RIVIAN SERVICE TOOL ENGINEERING

| DESCRIPTION | SUPPLIER + PART NUMBER | PHOTO |
|---|----------------------------|--|
| TWO ARM KNOB | MCMaster-CARR 65035K48 |  A black, T-shaped knob with a threaded stem. |
| QUICK RELEASE PIN 3/8" DIA, 3-1/2" USABLE LENGTH | MCMaster-CARR 98404A395 |  A long, thin metal pin with a small hole at one end and a ring at the other. |
| 3/8"-16 SCREW, 1" LONG | MCMaster-CARR 92240A624 |  A hexagonal head screw with a threaded shaft. |
| 3/8" ID WASHER | MCMaster-CARR 92141A051 |  A flat, circular metal washer with a central hole. |



TROUBLESHOOTING

| PROBLEM | SOLUTION |
|--|--------------------------------|
| FRONT HUB SUPPORT TOOL is bent or damaged. | Replace FRONT HUB SUPPORT TOOL |





DANGER

Risk of electrocution or electric shock



WARNING

Risk of minor injury



DANGER

Risk of major injury such as

- fire
- chemical or poison
- crushing / maiming
- death



CAUTION

Risk of

- damage to vehicle or property
- data disruption
- voiding warranty



CAUTION

Risk of Pinch Point

- keep hands and fingers clear of all moving parts.



PPE REQUIRED

IMPORTANT

Instructions to successfully complete a task

NOTE

Useful information

REVISION LOG

| REV | DATE | CHANGE DESCRIPTION |
|-----|-----------|--------------------|
| 1 | 5/13/2026 | Initial release |
| | | |

