

TOOL USE INSTRUCTION

RIVIAN

TOOL NUMBER	TSN01691-300
TITLE	BULB SEAL ROLLER
REV - DATE	REV 01 4/23/2026

CONTENTS

[OVERVIEW](#)

[SAFETY](#)

[INITIAL SETUP](#)

[TOOL USE INSTRUCTION](#)

[MAINTENANCE & STORAGE](#)

[SPARE PARTS](#)

[TROUBLESHOOTING](#)

[SYMBOL GLOSSARY](#)

TOOL FUNCTION

USED TO WET OUT ADHESIVE BACKED BULB SEAL ON THE R2 HV BATTERY ENCLOSURE AND POWERHOUSE

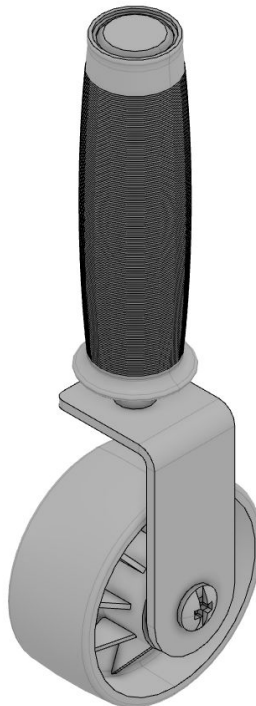

SPECIFICATIONS

Roller size: 73mm (2.875")
Spring force: 53 N (12 lbs)

LABOR CODES

301010010 - HV Battery (Remove and Replace)
301010011 - HV Battery (Remove and Reinstall)

OTHER TOOLS REQUIRED

TSN01698-300: R2 HV BATTERY BULB SEAL INSTALL TEMPLATE
TSN01274-100: 3M 07498 - DECAL REMOVER "STRIPE OFF" WHEEL

SAFETY



WARNING





Do not perform procedure if tool is damaged or missing parts. Consult the Rivian Service Tool Catalog for replacement components.

Failure to follow guidelines outlined in this document could result in injury and/or property damage.

SAFETY GUIDELINES

1	Always follow service manual procedure(s) to ensure vehicle is in a safe state prior to service	
---	---	--



<p>1</p>	<p>Install bulb seal according to service manual procedure and/or tool use instructions TSN01698-300 - BULB SEAL TEMPLATE</p> <p>Remove seal install template prior to using the seal roller</p>	
<p>2</p>	<p>Hold roller vertically and place against the seal with center of the wheel centered on the width of the seal.</p>	
<p>3</p>	<p>Apply downward pressure until the roller handle bottoms against the bracket.</p> <p>This ensures sufficient pressure is applied to fully wet-out the seal adhesive.</p>	
<p>4</p>	<p>While keeping handle compressed, slowly roll the tool along the full length of the seal.</p> <p>Ensure tool handle is vertical and roller remains centered on the seal at all times.</p>	

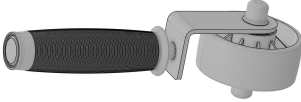
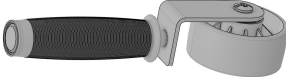

TOOL REVISION	IMAGE	WHAT CHANGED?
A		Initial release
B		Adds low profile hardware for wheel, eliminates 2x plastic caps

IMPORTANT

This roller was designed for installing the R2 main HV battery to body bulb seal.

In some cases, the R2 powerhouse bulb seal may also need to be replaced and rolled using the same amount of pressure.

REV A tools were found to clash with the powerhouse cover and need to be updated to REV B to gain tool clearance.

Refer to tool change order TCO-TSN01691-300-A for instructions to update REV A tools to REV B.



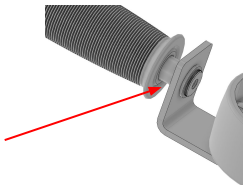

MAINTENANCE & STORAGE

TASK	FREQUENCY
Apply light oil to brass bushing at handle interface as needed to prevent the spring-loaded handle from sticking.	
Store in a dry environment	After each use



FOR OTHER ITEMS NOT SHOWN, CONTACT RIVIAN SERVICE TOOL ENGINEERING

ITEM	DESCRIPTION	SUPPLIER + PART NUMBER	PHOTO
1	SKATE WHEEL, 2.875" DIA	MCMaster-CARR 9960T71	
2	HANDLE GRIP	MCMaster-CARR 97045K45	
3	STEEL BINDING BARREL	MCMaster-CARR 98002A995	
4	BINDING BARREL SCREW	MCMaster-CARR 98002A430	

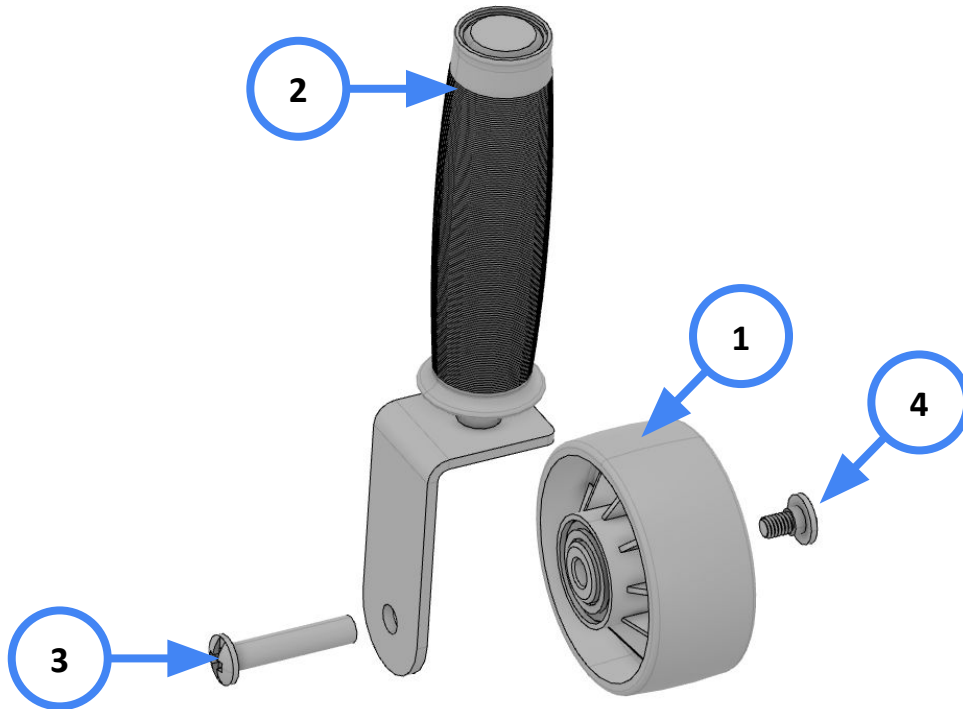



WARNING

Risk of minor injury

IMPORTANT

Instructions to successfully complete a task

NOTE

Useful information

REV	DATE	CHANGE DESCRIPTION
01	4/23/2026	Initial release

