

TOOL USE INSTRUCTION

RIVIAN

TOOL NUMBER

TSN01698-300

TITLE

R2 HV BATTERY BULB SEAL INSTALL TEMPLATE

REV - DATE

REV 01 4/13/2026

CONTENTS

[OVERVIEW](#)

[SAFETY](#)

[INITIAL SETUP](#)

[TOOL USE INSTRUCTION](#)

[MAINTENANCE & STORAGE](#)

[SPARE PARTS](#)

[SYMBOL GLOSSARY](#)

TOOL FUNCTION

USED TO LOCATE THE HV BATTERY TO BODY BULB SEAL ON R2 VEHICLES

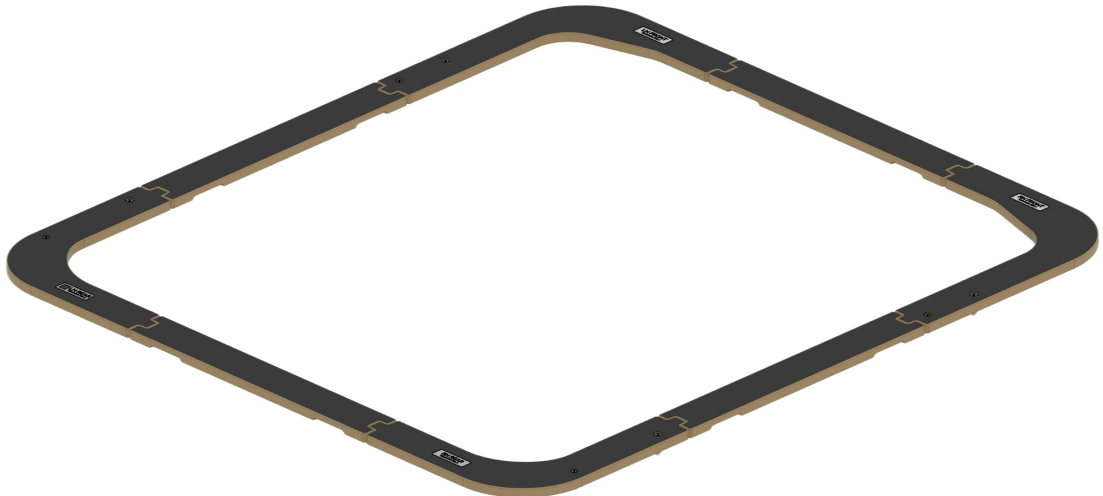

LABOR CODES

301010010 - HV Battery (Remove and Replace)
 301010011 - HV Battery (Remove and Reinstall)

STORAGE CONFIG



OTHER TOOLS REQUIRED

TSN01691-300 - BULB SEAL ROLLER
 3M 07498 - DECAL REMOVER "STRIPE OFF" WHEEL

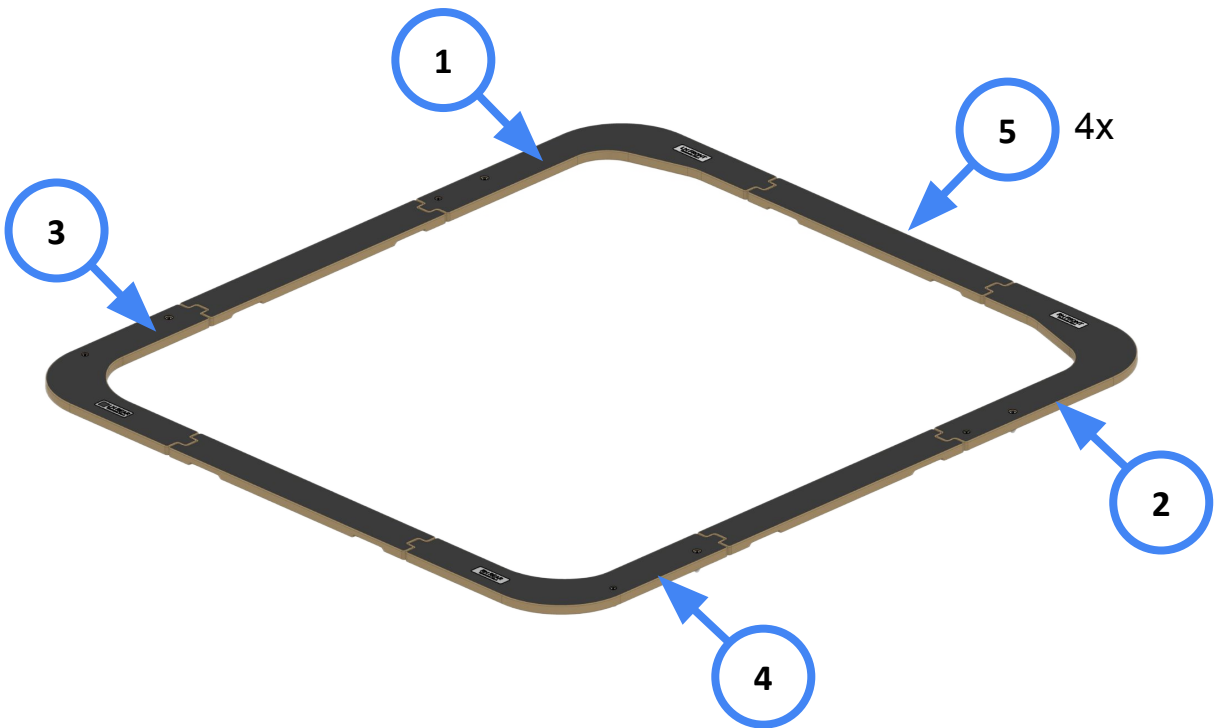

COMPONENT GUIDE

ITEM	QTY	RIVIAN TOOL ID	DESCRIPTION
1	1	TSN01698-200	LH FRONT CORNER PANEL
2	1	TSN01698-201	RH FRONT CORNER PANEL
3	1	TSN01698-202	LH REAR CORNER PANEL
4	1	TSN01698-203	RH REAR CORNER PANEL
5	4	TSN01698-204	STRAIGHT PANEL





WARNING

Do not perform procedure if tool is damaged or missing parts. Consult the Rivian Service Tool Catalog for replacement components.

Failure to follow guidelines outlined in this document could result in injury and/or property damage.



SAFETY GUIDELINES

1	Always follow service manual procedure(s) to ensure HV battery is in a safe state prior to service	
---	--	---

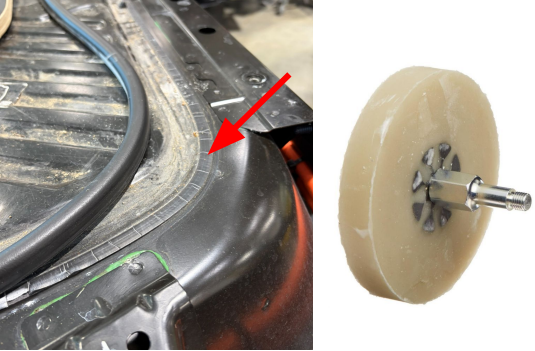
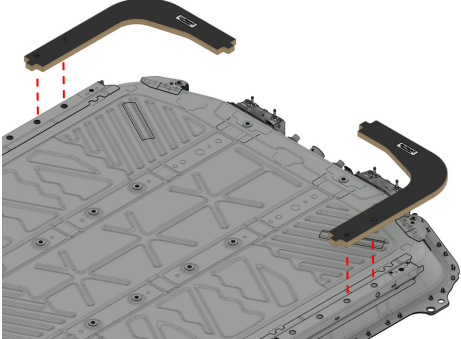
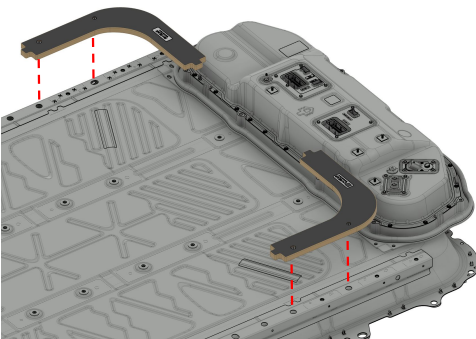
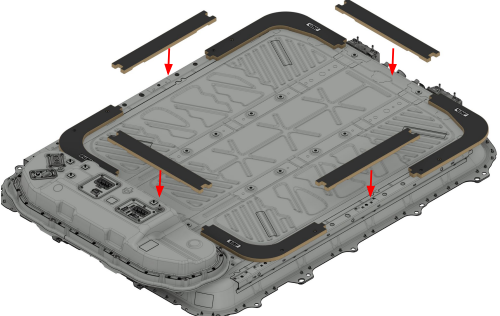

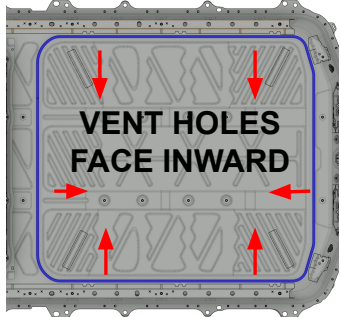
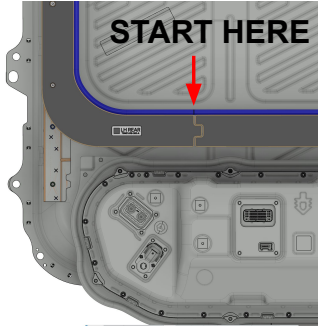

<p>1</p>	<p>Prep the surface of the HV battery:</p> <ul style="list-style-type: none"> ● Peel away + discard existing seal ● Remove residual adhesive using 3M 07498 decal remover mounted to a cordless drill ● Wipe surface with isopropyl alcohol to remove any remaining residue and debris 	
<p>2</p>	<p>Install front corner template panels in locations shown</p>	
<p>3</p>	<p>Install rear corner template panels in locations shown</p>	
<p>4</p>	<p>Install 4x straight panels between each corner panel to complete the template assembly.</p>	



<p>1</p>	<p>Inspect replacement seal, ensure no signs of damage.</p> <p>Observe small vent holes in the seal and orient holes inward, toward the dry side of the pack.</p>	
<p>2</p>	<p>Peel away a short section of the seal adhesive and begin laying down the seal.</p> <p>Start at the LH rear of the pack, where LH rear corner panel meets the straight panel.</p>	
<p>3</p>	<p>Work clockwise to lay the seal down in sections, exposing only as much adhesive as needed.</p> <p>NOTE</p> <p>Use gentle pressure to align the seal against the side of the template before pressing downward to adhere to the pack.</p> <p>Excessive inward pressure on the seal may result in twisting/waviness.</p>	
<p>4</p>	<p>Cut the end of the seal - ensuring cut is square and sits flush to the starting point.</p>	

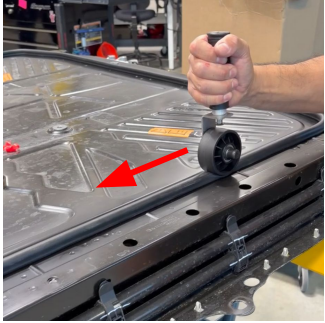

<p>5</p>	<p>Remove seal template panels. Use TSN01691-300 bulb seal roller to roll the full length of the seal.</p>	
<p>6</p>	<p>Immediately prior to installing the pack to the vehicle, apply RTV to the splice joint. Refer to service manual for RTV adhesive spec and application method.</p>	

MAINTENANCE & STORAGE

TASK	FREQUENCY
<p>Inspect templates for signs of wear or damage. Replace panels and / or locating buttons as needed.</p>	<p>Prior to use</p>
<p>Use 4x velcro straps to bundle panels, store panels in provided soft-shell bag.</p>	<p>After use</p>

STORAGE CONFIG



FOR OTHER ITEMS NOT SHOWN, CONTACT RIVIAN SERVICE TOOL ENGINEERING

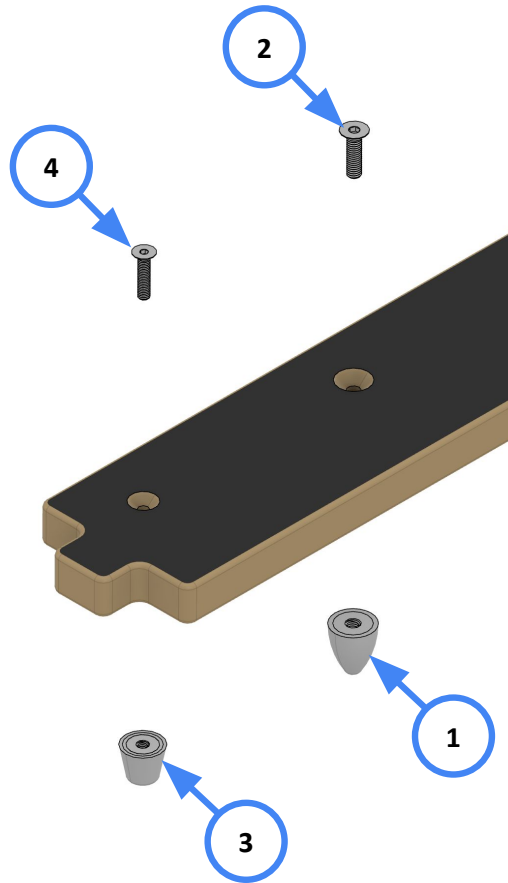

ITEM	DESCRIPTION	SUPPLIER	PART NUMBER
1	20mm CONE LOCATING BUTTON	MCMaster-CARR	9377K459
2	M6 COUNTERSUNK SCREW	MCMaster-CARR	91263A891
3	19mm TAPERED LOCATING BUTTON	MCMaster-CARR	9377K523
4	M5 COUNTERSUNK SCREW	MCMaster-CARR	91263A881





WARNING

Risk of minor injury

IMPORTANT

Instructions to successfully complete a task

NOTE

Useful information

REV	DATE	CHANGE DESCRIPTION
01	4/13/2026	Initial release

